

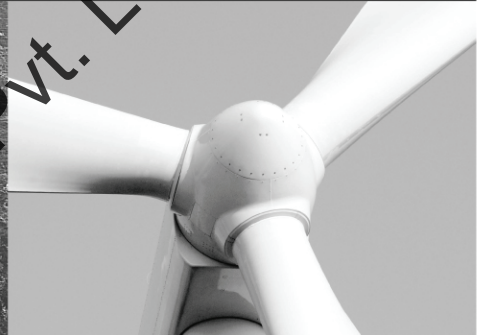

Control Electric Co. Pvt. Ltd.
Tel No:(+91)120-4217189,09818689117
sales@plcpanel.com, www.plcpanel.com

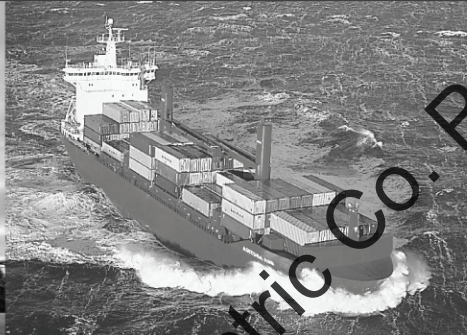

Load Sharing Units



Control Electric Co. Pvt. Ltd.

Control Electric Co. Pvt. Ltd.
Tel No:(+91)120-4217189,09818689117
sales@plcpanel.com
www.plcpanel.com

ANSI code 90
Type LSU-112DG

- **For control of diesel and gas generators**
- **Built-in power and frequency transducer**
- **Constant power or isochronous mode**
- **LED indication of status**
- **LED indication for activated control**
- **35 mm DIN rail or base mounting**

Application

The LSU-112DG is a control unit for control of the prime mover in a power unit.

The LSU-112DG can control the power unit

- in stand-alone mode, performing frequency control
- parallel with grid, performing power control
- parallel with other power units, performing frequency and power control

The unit is designed for connection to a mechanical speed governor, however in conjunction with the DEIF electronic potentiometer type EPN-110DN or EPO-96 it can control electronic speed governors as well.

The LSU-112DG has a built-in frequency transducer. If a very stable frequency is wanted, an external frequency transducer common for all the LSU-112DGs in the power plant can be connected. If a number of power units are to be synchronised to the busbar at the same time, the frequency may likewise be controlled externally.

Function

The LSU-112DG is measuring the voltage and the current from which the frequency and the power produced by the power unit are measured. The built-in power transducer is based on an $I \times \cos \phi$ principle.

The following couplings are available:

- 1W(4) – single phase
- 1W3 – 1 element 3 phase, 3 wire, balanced load

If unbalanced load can be expected, an external power transducer with an output of 4...20mA can be connected to the LSU-112DG. In this case the built-in $I \times \cos \phi$ transducer is automatically interrupted.

The power and frequency measured by each LSU-112DG are fed to 2 paralleling lines for comparison with the frequency (FS) and power (PS) of the other connected LSU-112DG.

If L1 or L2 is disconnected from the LSU-112DG at the same time as a power unit in a power plant is disconnected from the power line (busbar), built-in relays in the LSU-112DG ensure that the power output and the frequency output of the associated unit are disconnected from the paralleling lines. Likewise the power and frequency outputs are disconnected if the auxiliary voltage to the LSU-112DG is disconnected.

Load sharing units

uni-line

4921240118F

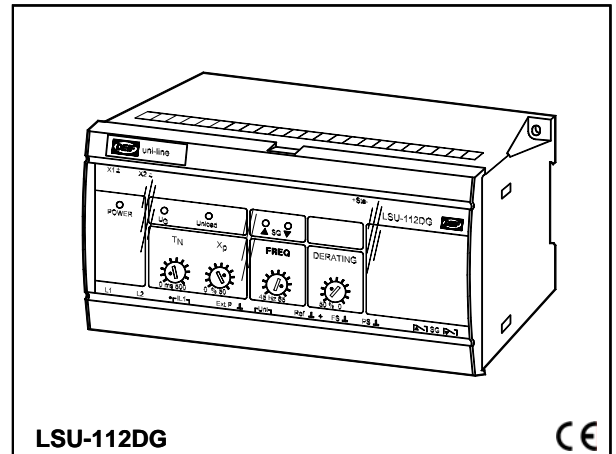

The LSU-112DG is equipped with an unload input. When activated this input will control the power unit to zero power, and at the same time the power output of the LSU-112DG is disconnected from the paralleling line.

The calibration of the LSU-112DG is done so it matches its power unit. This means that load sharing between power units with different size will be performed according to the actual size of the individual power unit in the plant. E.g. a 100kW PU and a 150kW PU running in parallel will share a total load of 125kW into 50kW and 75kW. If the 150kW PU is derated to 100kW by means of the DERATING potentiometer on the front of the LSU-112DG, the load in the above example will then be shared equally between the 2 power units.

Regulator output

The unit is provided with 2 contact outputs for speed control:

Power and frequency control:

The regulating speed of the servomotors for the prime mover is controlled by the built-in P controller of the LSU-112DG according to its setting for:

T_N (pulse length):

The min. duration of the control pulse.

X_P (proportional band):

The zone within which the pulse/pause ratio changes proportionally to the frequency/power deviation from the required value.

Dead band:

The zone within which no control pulses are emitted:

Power: $\pm 0.5\%$ of P_n (or for derated value)

Frequency: $\pm 0.1\text{Hz}$

Self-monitoring

The LSU-112DG is equipped with a self-monitoring function. The function supervises the built-in micro-controller and hereby verifies if the programme is running correctly. The green LED marked "POWER" is connected to this function. Constant green light indicates that the supply voltage is accepted and the unit is running correctly. Flashing green light 2-3Hz indicates that the supply voltage is accepted but the unit is running incorrectly. In this situation the status output terminals 17 and 18 are activated (open).

Type LSU-112DG

Terminals/function

Connection type	Connect	
1W3 (standard)	L1 to term. 24	L2 to term. 26
1W (betw. phase/neutral)	L1 (P) to term. 24	Neutral to term. 26

Terminal no.	Description/action
1 and 3 X1/X2	Input for supply voltage
17 and 18 Sta	Status output, activated (closed) when the supply voltage is connected and the unit is working correctly
28 and 29 IL1	Input for the current measurement. Note that S1 on the external current transformer is connected to terminal 28, and S2 is connected to terminal 29
31 and 32 Ext. P.	Must be short-circuited, if the internal power transducer is used (normal). For applications with unbalanced load it is recommended to use an external power transducer (replacing the built-in one). Connect external power transducer to 31 (+) and 32 (-). The output of the external transducer must be 4...20mA DC. The output of the connected transducer must limit the output to min. 2mA and max. 22mA. DEIF transducer type TAS-331DG is recommended
33 and 34 ("Unl")	May be connected to a potential-free N/O relay contact. When this contact is activated, the power of the generator is regulated to zero (unloading) and the LSU-112DG is disconnected from the PS power line
35 ("Ref.")	Reference input. Must be connected to term. 36 ("⊥"), if not used. This input is used to control the power unit running in power control mode (fixed load to grid). A +0.5V...5V connected to the input with respect to ⊥ will control the PU in the range 10...100% power. The input activates at 0.55V and deactivates at 0.45V. Please notice that when this input is active the LSU-112DG is still connected to the PS and FS lines. In this mode the PS line acts only as an output
37 ("+5V")	Reference output. This voltage output can be used for local power control mode. If terminal 37 is feeding a voltage divider, and the output from the voltage divider is connected to terminal 35, local power control can be performed
36 ("⊥")	Common earth terminal for the above reference input/output
38 (FS) and 39 ("⊥")	Paralleling line for frequency sharing of the connected LSU-112DGs
40 (PS) and 41 ("⊥")	Paralleling line for power sharing of the connected LSU-112DGs. Normally 5V at nominal busbar voltage and cos phi = 1. If cos phi 0.8 is stated on the label, 4V correspond to 100% power
43 and 44 Relay contacts "SG"	Relay contact for increase of the speed
45 and 46 Relay contacts "SG"	Relay contact for decrease of the speed
NOTE: Relay contacts	Relays (SG) should always be connected via external auxiliary relays when a DC pilot motor is applied. A transient suppressor should always be connected across the relay coil of the external relays

NOTE:

All terminals marked "⊥" are internally connected.

For correct function of the LSU-112DG any analogue DC input must not exceed 110% of its nominal value. To ensure correct power measurement it is important that the AC current input does not exceed 110% of its nominal value. To accomplish this it is important to take the value of the max. cos phi into consideration when ordering/configuring the LSU-112DG, e.g. by using the kVA figure of the generator and cos phi = 1.

Application

The schematic drawings on the next page show the different couplings for the LSU-112DG. For further information see the Application notes for uni-line, doc. no. 4189340150.

Copyright © Electric Co. Pvt. Ltd.

Type LSU-112DG

Schematic drawings

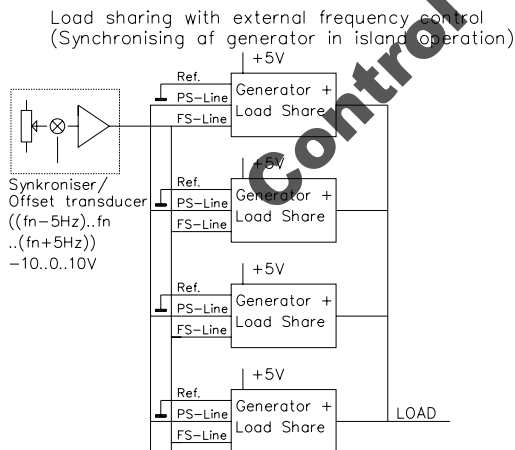
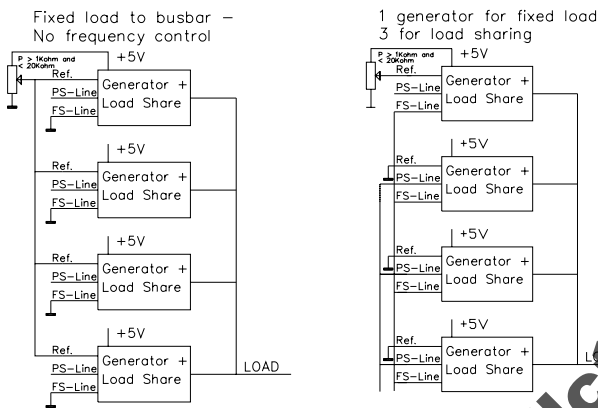
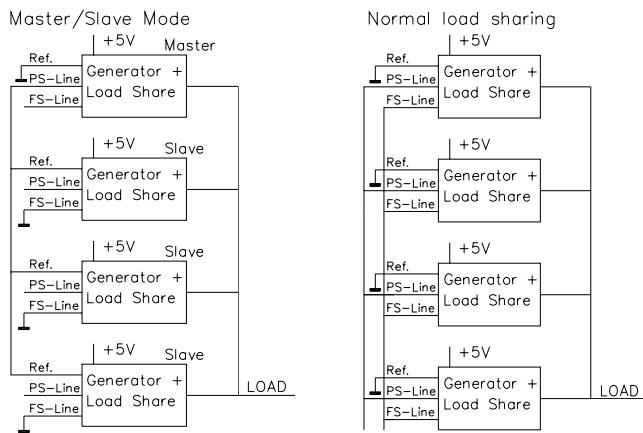

Technical specifications

- Meas. current (I_n):** 0.3-0.4-0.5-0.6-0.8-1.0-1.3-1.5-2.0-2.5-3.0-4.0-5.0A AC (calibration modules)
 UL/cUL listed: 0.4...5.0A AC
- Adjusted range:** 75...100% of I_n (e.g. 0.45, adjusted by means of a built-in potentiometer)
 (Lowest meas. range: 0.3A)
- Overload:** 4 x I_n , continuously
 20 x I_n for 10 s (max. 75A)
 80 x I_n for 1 s (max. 300A)
- Load:** Max. 0.5VA (per phase) at I_n
- Meas. voltage (U_n):** (See supply voltage - AC ranges)
- Voltage range:** U_n 60...120%
- Overload:** 1.2 x U_n , continuously
 2 x U_n for 10 s
- Load:** 2kVA
 UL/cUL listed: 57.7...450V AC
- Frequency range:** 40...45...65...70Hz
- Inputs:**
Unload: Potential-free relay contact
 Open: 5V. Closed: 5mA
 UL/cUL listed:
 +/-5V DC (using pot. free ext. contacts)
- Reference input:** 0.5...5V \pm 1% (10...100% power)
 Input resistance: \geq 2M Ω
- Ext. power input:** 4...20mA DC \pm 2%
- Ext. frequency input:** -5...0...5V \pm 2% ~ 0... \pm 2.5Hz
 Max. -10...0...10V ~ -5...0...5Hz
- Contact outputs:**
Speed control: 2 make contacts
- Contact ratings:** AC1/DC1: 250V AC/24V DC, 8A
 AC15/DC13: 250V AC/24V DC, 3A
 UL/cUL listed: Resistive load only
- Life electrical:** 1 x 10⁵ (nominal value)
- Analogue outputs:**
PS line, FS line: 2 parallel, analogue lines (-5...0...5V)
 5V \pm 2% = 2.5Hz ~ 100% power
 0V \pm 2% = 0Hz ~ 0% power
- Reference output:** Reference voltage: 5.0V \pm 1%
 Load: Max. 5mA ($R \geq$ 1k Ω)
 UL/cUL listed: +/-5V DC
- Optocoupler output:** System status off = Failure
 Max. voltage 30V DC, max. current 5mA
 Voltage drop 1.5V ~ 2mA
 UL/cUL listed: 30V DC, 5mA
- Temperature:** -25...70°C (-13...158°F) (operating)
 UL/cUL listed:
 Max. surrounding air temp. 60°C/140°F

Type LSU-112DG

Technical specifications, continued

Temperature drift:	Set-points: Max. $\pm 0.2\%$ of full scale per $10^{\circ}\text{C}/50^{\circ}\text{F}$
Galvanic separation:	Between meas. voltage, meas. current, relay outputs, analogue inputs/outputs and aux. voltage: 3250V - 50Hz - 1 min.
Supply voltage (U_n):	57.7-63.5-100-110-127-200-220-230-240-380-400-415-440-450-660-690V AC $\pm 20\%$ (max. 3.5VA) 24-48-110-220V DC -25/+30% (max. 2.5W) UL/cUL listed: Only 24V DC and 110V AC DC supply must be from a class 2 power source
Climate:	HSE, to DIN 40040
EMC:	To EN 61000-6-1/2/3/4, SS4361503 (PL4) and IEC 255-3
Connections:	Max. 4mm ² (single-stranded) Max. 2.5mm ² (multi-stranded)
Materials:	All plastic parts are self-extinguishing to UL94 (V1)
Protection:	Case: IP40. Terminals: IP20, to IEC 529 and EN 60529
Type approval:	The uni-line components are approved by the major classification societies. For current approvals see www.deif.com or contact DEIF A/S
UL markings:	Wiring: Use 60/75°C (140/167°F) copper conductors only Wire size: AWG 12-16 or equivalent Installation: To be installed in accordance with the NEC (US) or the CEC (Canada)

Settings

Setting of	Range
T _N Control pulse length	25...500 ms
X _P Proportional band	0... $\pm 50\%$ of P _n 0... $\pm 2.5\text{Hz}$ of set frequency
Frequency	45...65Hz
Derating	50...0% of P _n

Indication

LEDs	Lit	Switched off
U _G Generator voltage	(Green) Present	Failure
Unload Unloading of this generator	(Green) Gen. unloaded	Normal load
SG▲ Increase speed (power)	(Yellow) Relay activated	Relay not activated
SG▼ Decrease speed (power)		

Once the unit has been mounted and adjusted, the transparent front cover may be sealed, preventing unwanted change of the setting.

Connections/dimensions (in mm)

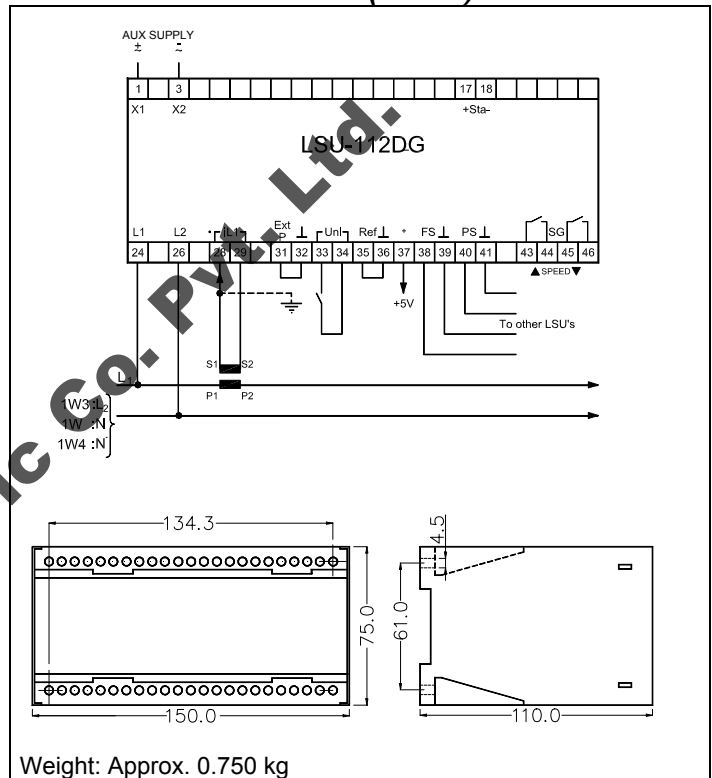

Order specifications

Type – Coupling – Measuring power (P_n) – Cos-phi – Measuring voltage – Supply voltage

Example:

LSU-112DG – 1W3 – 100W – 0.8 – 100V – 24V DC

$$\text{Meas. power} = \frac{\text{Primary power}}{\text{CT ratio} \times \text{VT ratio}}$$