



Lexan® Sheet®
9030 • Exell D ST • Exell D • Margard

Technical Manual Glazing

Lexan

Contents

Introduction	2	General Guide-lines	16
Product Profile	3	Storage	16
Product Range	4	Handling	16
Typical Mechanical Properties of Lexan® Sheet	5	Cutting and Sawing	16
Lexan® solid sheet	5	Circular Saws	16
Properties vs Temperature	5	Bandsaws	16
Impact strength	5	Jig Saws and Hacksaws	16
GE falling dart impact test	5	Drilling	16
Steel Ball Impact Test	6	Wind and Snow Loading	17
Balcony Glazing Test	6	Dynamic Wind Pressure	17
Physical Properties	7	Pressure Coefficient	17
Light Transmission	7	Snow Loading	17
Clear Lexan® solid sheet	7	Computer Aided Sheet Engineering	17
UV Protection	7	Wind and Snow Loading Consideration	17
Solar Heat Gain	8	Installation	18
Solar Control	8	Thermal Expansion Allowance	18
Solar Heat Gain	8	Sheet Edge Engagement/Rebate	18
Temperature Resistance	8	Depth Requirements	18
UL Ratings	8	Flat Glazing Installation	19
Abrasion Resistance	9	Glazing Systems	19
Sound and Thermal Properties	10	Wet Glazing Systems	19
Single Glazing	10	Dry Glazing Systems	19
Double Glazing	10	Sheet Glazing Guide-lines	20
Energy Loss Calculation	10	Wet Glazing	20
Single Glazing	10	Dry Glazing	20
Double Glazing	10	Flat Glazing Installation	21
Triple Glazing	10	Overglazing Double Glazing	21
Miscellaneous Properties	11	Internal Overglazing	21
Light Weight	11	External Overglazing	21
Fire Performance	12	Double Glazing Units	21
Large-scale roof test	12	Flat Glazing Sheet Thickness Selection	22
National Standards	12	Site Safety	23
Chemical Resistance	13	Curved Glazing Installation	24
Cleaning	14		
Cleaning	14		
Cleaning Lexan® Margard®	15		

Product Profile

For over 25 years the high performance properties of Lexan® polycarbonate resin have provided the plastics industry with a sheet material unmatched in terms of clarity, impact resistance, temperature resistance and structural strength.

GE Structured Products is the sheet and film division of GE Plastics, with European headquarters and manufacturing site in the Netherlands. Additional manufacturing operations are based in Italy and Austria, and sales and marketing facilities are strategically located throughout Europe.

GE Structured Products' range of Lexan sheet products, directly extruded from Lexan polycarbonate resin, offers significant advantages over many other glazing materials in terms of design freedom, light-weight, fire performance and thermal insulation.

Furthermore, Lexan sheet combines high impact resistance with optical clarity, so providing superior safety and security protection against vandalism and intrusion.

Lexan® 9030

Lexan 9030 polycarbonate is the standard sheet grade for transparent protective glazing. Used for either primary or secondary glazing for added protection against breakage or intrusion, it is a better insulator than glass and is easily fabricated for a wide range of indoor applications, machine guards or vandal-proof street furniture.

Lexan® Exell® D ST

Lexan Exell D ST sheet is an UV protected, translucent product that yields excellent light diffusion. Its pebbled surface provides the ideal solution for privacy glazing with all the performance characteristics of standard Lexan polycarbonate. Lexan Exell D ST is backed by a 10 year limited warranty*.

Lexan® Exell® D

Lexan Exell D is a transparent polycarbonate sheet with proprietary UV protection on both sides. With its excellent weathering properties and outstanding impact resistance, it is ideally suited to a wide variety of building and construction applications.

Lexan Exell D sheet can be easily cold-formed into gentle curves which makes it ideal for skylights, covered walkways, barrel vaults, etc. Lexan Exell D can be thermoformed into the desired geometry whilst retaining the UV resistant coating specially developed for weather resistant applications. The superior UV resistance and toughness of Lexan Exell sheet is backed by a 10 year limited warranty* against yellowing, loss of light transmission and breakage.

Lexan® Margard® MR5-E

Mar/UV resistant Lexan Margard MR5-E sheet combines the impact strength of Lexan polycarbonate sheet with a proprietary abrasion/UV resistant surface that is close to glass in performance. It is the only polycarbonate glazing material that is backed by a

five year warranty* against yellowing, loss of light transmission and coating failure, and by a ten year warranty* against breakage.

Lexan Margard sheet is immune to contact with many chemicals such as cleaning fluids, paints and adhesives. Its unique coating "defies graffiti to stick", enabling restoration to a 'good-as-new' condition. In addition, Lexan Margard MR5-E sheet offers improved resistance to weathering as well as forced entry protection. It is ideal for use in shops, public buildings, schools, bus shelters and other high traffic areas.

Flat applications only

Due to its mar-resistant coating, Lexan Margard MR5-E sheet cannot be cold-formed. The sheet is intended for flat applications only.

Abrasion resistance

Tested for abrasion resistance, Lexan Margard MR5-E sheet exhibits significantly less hazing than uncoated polycarbonate sheet.

Lexan® Margard® MRA3

Lexan Margard MRA3 combines the impact strength of Lexan Polycarbonate sheet with a proprietary unique abrasion resistant service on both sides. Lexan Margard MRA3 is immune to contact with many chemicals such as cleaning fluids, paints and adhesives. Its improved resistance to abrasion as well as its high impact resistance makes it ideal for use as secondary glazing (interior), in public buildings, schools etc. and as machineguard glazing.

Flat applications only

Due to its mar-resistant coating, Lexan Margard MRA3 sheet cannot be cold-formed. The sheet is intended for flat applications only.

Abrasion resistance

Tested for abrasion resistance, Lexan Margard MRA3 sheet exhibits significantly less hazing than uncoated polycarbonate sheet.

Lexan® Margard® Sheet FMR5-E (Formable)

Lexan Margard FMR5-E is a transparent UV and abrasion resistant glazing material offering:

- Extremely high impact strength, with the capacity to be cold-curved or drape-formed.
- Dual hardcoated surface offering resistance against wear and tear.
- High resistance to chemicals
- Unique ten year warranty* against breakage.
- Five year warranty* against yellowing, loss of light transmission and coating failure.

Processing

Lexan Margard FMR5-E can be cold-curved into shallow radii. It can also be drape-formed at a maximum temperature of 155°C, normally without pre-drying.

**See Warranty for exact details.*

Product Range

Curved applications

Design freedom, light weight and optical clarity combined with superior mechanical properties make Lexan Margard FMR5-E the ideal glazing material for shaped applications such as curved windows, (e.g. revolving doors), partitions, skylights, barrel vaults, balcony glazing, stairglazing, shelters and machine safety guards.

Optical performance

Clear Lexan glazing offers excellent clarity and has the highest transmission in the visible light and near infra-red region of the spectrum. As it is essentially opaque to all wavelengths below 385 nanometres, it is ideal for protecting art, antiques, retail displays and fabrics from the damaging effects of UV rays.

Lexan solid sheet is normally manufactured in the standard sizes and colours listed below. Ex-stock delivery of these and cut-to-size sheet is available through GE Structured Products' wide network of specialist stockists.

Different colours and dimensions can be made available by prior arrangement. Such arrangements may affect prices and conditions of sale.

Lexan 9030

Standard gauge in mm 3-4-5-6-8-9,5-12	
Standard colours	Light transmission*
<ul style="list-style-type: none"> clear code 112 solar bronze code 5109 solar grey code 713 opal white 	73-87% dep. on thickness 50% all thicknesses 50% all thicknesses 9-65% dep. on thickness
Standard sizes:	
1250 x 2050 mm 2050 x 3000 mm 2050 x 6000 mm	
Masking:	
Top side:	Polystick white PE Grey/red print
Bottom side:	Polystick transparent
* Subject to a tolerance of 5%	

Lexan Margard MR5-E/Lexan Margard FMR5-E

Standard gauge in mm 3-4-5-6-8-9,5-12	
Standard colours	Light transmission*
<ul style="list-style-type: none"> clear code 112 solar bronze code 5109 	73-87% dep. on thickness 50% all thicknesses
Standard sizes:	
2000 x 3000 mm	
<i>Note: for some applications the ripple orientation may play an important role in the optical performance of the sheet. This orientation is indicated on the masking.</i>	
* Subject to a tolerance of 5%	

Lexan Margard MRA3

Standard gauge in mm 2-3-4-5-6**	
Standard colours	Light transmission*
<ul style="list-style-type: none"> clear code 112 	89,5-86% dep. on thickness
Standard sizes:	
1220 x 3000 mm (gauges < 3mm) 2000 x 3000 mm (gauges > 2mm)	
* Subject to a tolerance of 5%	
** other gauges upon request.	
<i>Note: for some applications the ripple orientation may play an important role in the optical performance of the sheet. This orientation is indicated on the masking.</i>	

Lexan Exell D ST

Standard gauge in mm 3-4-5-6-8	
Standard colours	Light transmission***
<ul style="list-style-type: none"> clear code 112 solar bronze code 5109 	84-87% dep. on thickness 50% all thicknesses
Standard sizes:	
1250 x 2050 mm 2050 x 3000 mm	
Masking:	
Top side:	Non
Bottom side:	Coex. transparent PE
<i>Note: top side is textured</i>	
* Subject to a tolerance of 5%	
** * translucent = letting light pass through but not transparent	

Lexan Exell D

Standard gauge in mm 3-4-5-6-8-9,5-12	
Standard colours	Light transmission*
<ul style="list-style-type: none"> clear code 112 solar bronze code 5109 solar grey code 713 opal white code 82939 opal white code 82943 	84-87% dep. on thickness 50% all thicknesses 50% all thicknesses 50% all thicknesses 25% all thicknesses
Standard sizes:	
2050 x 3000 mm 2050 x 6000 mm	
Masking:	
Top side:	Coex. transparent PE
Bottom side:	Coex. transparent PE
* Subject to a tolerance of 5%	

Typical Properties of Lexan® Sheet

Lexan solid sheet

Lexan solid sheet exhibits an excellent balance of physical, mechanical and environmental properties which are maintained over a wide range of temperature and humidity conditions.

Specifics on the properties of these products are dealt with in this section.

Table 1: Typical Properties Lexan solid sheet

	Standard	Unit	Lexan Solid Sheet
Physical Properties Specific gravity	DIN 53479		1.20
Mechanical Properties Tensile strength at yield	DIN 53455	N/mm ²	>60
Tensile strength at break	DIN 53455	N/mm ²	>70
Elongation at yield	DIN 53455	%	6-8
Elongation at break	DIN 53455	%	>100
Flexural modulus	DIN 53457	N/mm ²	2500
Flexural yield strength	DIN 53452	N/mm ²	100
Impact strength (falling dart)*	GE Method	Nm	>200
IZOD notched (1/8") at room temp.	ASTM D 256	J/m	600-800
Thermal Properties Heat resistance temperature: Vicat VST/B	DIN 53460	°C	>145-150
DTUL 1,82 N/mm ²	ASTM D 648	°C	135-140
Coeff. of linear thermal expansion	VDE 0304/1	m/m°C	6.7 x 10 ⁻⁵
Thermal conductivity	DIN 52612	W/m°C	0.21

*Measured on injection moulded test specimens.

Fig. 1: Stress-strain diagram for Lexan solid sheet

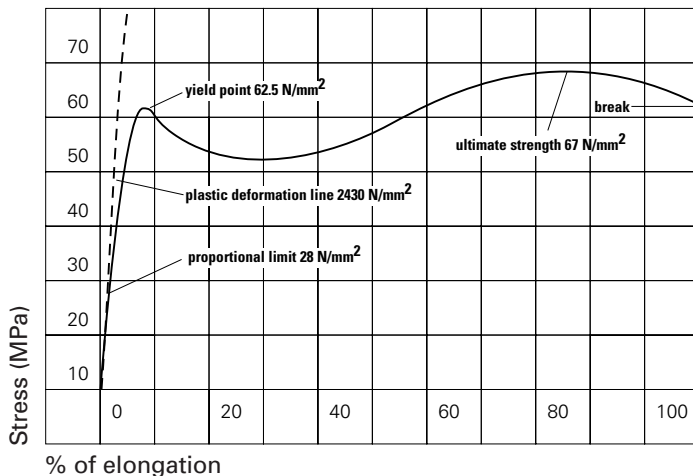

Properties vs Temperature

range of temperatures.

Lexan solid sheet is characterised by its excellent mechanical behaviour, maintaining high strength and stiffness when exposed to elevated temperatures over a long period of time. For example Lexan solid sheet retains 85% of its room temperature flexural modulus at 82°C. Figure 2 shows flexural modulus as a function of temperature.

An outstanding feature of Lexan solid sheet is the retention of mechanical properties over a wide

Fig. 2: Flexural modulus vs temperature

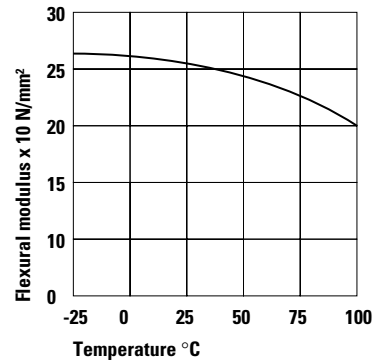

Impact strength

Lexan polycarbonate sheet is one of the toughest, transparent thermoplastic materials. It withstands impact from all kinds of objects, from stones to hammers without shattering. Its proven energy absorbing characteristics are maintained at sub-zero winter temperatures or high summer temperatures. Polycarbonate sheet has 250 times the impact strength of glass and so gives greater protection against vandalism and forced entry.

GE falling dart impact test

When tested to the GE "falling dart" impact strength test, Lexan polycarbonate sheet provided superior energy absorption, (>200 N), compared to other types of plastic glazing materials. A dart of 8 kg, with a hemi-spherical top of 12.5 mm radius is freely dropped from a height of 2.5 m onto a Lexan sheet disc. The Lexan sheet disc is freely supported at the edges and has a diameter of 100 mm and a thickness of 3.2 mm.

Speed of falling dart

$$V = 2gh$$

$$= 2 \times 10 \times 2,5 = 7 \text{ m/sec or } 25,2 \text{ km / hour}$$

$$M = \text{Falling dart mass} = 8 \text{ kg}$$

$$h = \text{Drop height} = 2,5 \text{ m}$$

$$E = M \times gh$$

$$= 8 \times 10 \times 2,5 = 200 \text{ Nm}$$

Fig. 3: GE falling dart impact test

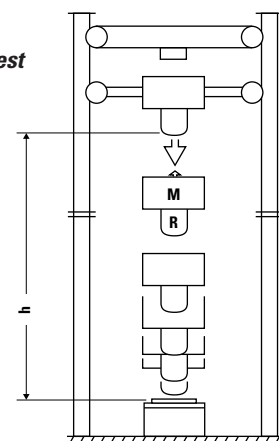

Mechanical Properties

Across the glazing sheet range, which includes Lexan Exell D, Lexan Margard MR5-E and FMR5-E, Lexan 9030 sheet and Lexan Exell D ST sheet, the outstanding toughness offers superior protection against breakage. The entire product range meets the highest impact performance required by the European Norm prEN356 for security glazing.

Norm prEN356

Steel Ball Impact Test A steel ball of 4.11 kg with a diameter of 100 mm is dropped freely from different defined heights onto the glazing specimen. In each class the steel ball must impact the specimen three times. The glazing material fulfils the requirements of the test if all impacts do not cause penetration by the steel ball. The relative classes, drop height requirements and test results are outlined in Table 2 with a diagrammatic representation of the test shown in Figure 4. Each of the products tested reached the highest standard required by the test at a thickness of 5 mm and above.

Fig. 4: Steel Ball Impact Test

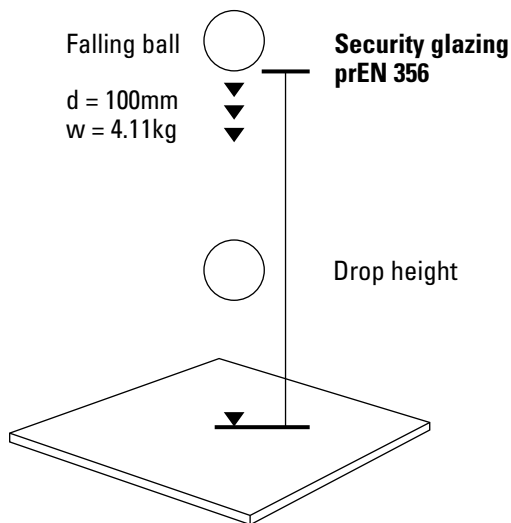

Balcony Glazing Test – DIN 52337 Soft and Hard Body Impact

Two different aspects of this particular test simulate the types of impact that may occur on infill glazing panels

for balustrades and walkways. The soft body impact involves a pendulum test with a weight of 45 kg being released from a drop height of 1.5 metres onto the specimen. The hard body impact simulates a point-load situation with a pear shaped specimen weighing 10 kg being released from a height of 1.5 metres. In both cases the impactor must not penetrate the glazing panel which should remain in position. All solid sheet with a thickness of 6 mm and above complies with the highest standards of the test.

Fig. 5: Balcony Glazing Test
DIN 52337 Hard/Soft Body Impact

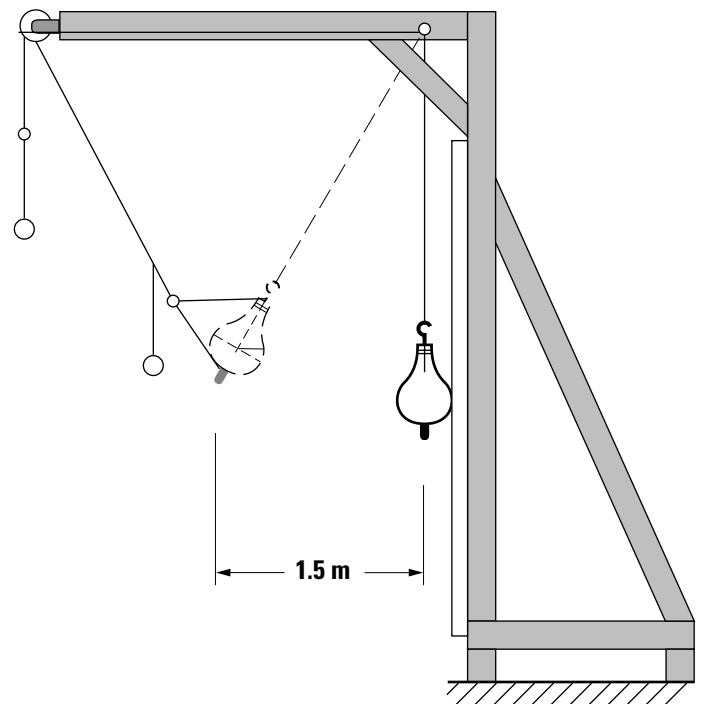

Table 2

Category of resistance	Drop height mm	Total number of strikes	Code designation for category of resistance	Impact energy per stroke
P1A	1500	3 in a triangle	EN 356 P1A	62 Joule
P2A	3000	3 in a triangle	EN 356 P2A	123 Joule
P3A	6000	3 in a triangle	EN 356 P3A	247 Joule
P4A	9000	3 in a triangle	EN 356 P4A	370 Joule
P5A	9000	3 x 3 in a triangle	EN 356 P5A	370 Joule

Classification table for the resistance of security glazing products according to European Norm prEN356

Physical Properties

Optical Performance

Light Transmission

The sunlight which reaches the surface of the earth has a wavelength that ranges between 295 – 2140 nanometres (10^{-9} metres).

The optical window is divided into the following sections.

UV-B Middle UV Region	280 - 315 nm
UV-A Near UV Region	315 - 380 nm
Visible Light Region	380 - 780 nm
Near Infra-red Region	780 - 1400 nm
Middle Infra-red Region	1400 - 3000 nm

As shown in Figure 6, Lexan sheet products have the highest transmission in the visible light and near infra-red region of the spectrum.

Lexan polycarbonate sheet products are essentially opaque to all wavelengths below 385 nanometres. Lexan solid sheet glazing can therefore be used to shield sensitive materials such as fabrics or other organic materials against discolouration in environments such as factory warehouses, museums or shopping centres.

Fig. 6: Light Transmission Spectrum of Lexan Polycarbonate

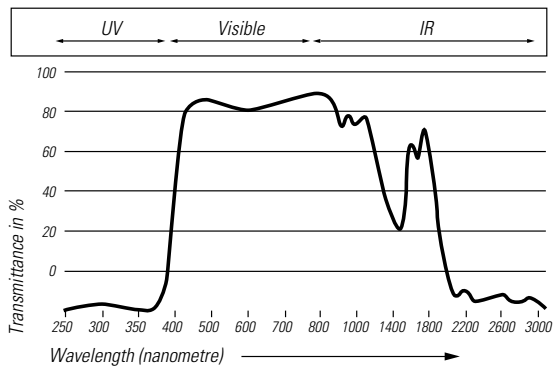

Clear Lexan solid sheet

Clear Lexan solid sheet offers excellent clarity almost approaching that of glass, with light transmission values of 75 – 87%, depending upon the thickness of sheet. However, for buildings in hot climates or with south facing aspects, Lexan solid sheet is available in translucent grades of bronze, grey and opal white.

Environmental factors

UV Protection

Solar radiation has a particularly harmful effect upon polymeric materials by initiating degradation through superficial surface crazing. These crazes become sites for further erosion from water, dust, chemicals, etc.

The degree to which these conditions affect the polymer depend largely upon environmental parameters such as geographical location, altitude, seasonal variations etc.

Lexan Exell D and Lexan Exell D ST sheet have proprietary UV-protected surfaces, giving excellent resistance to outdoor weathering. The unique proprietary technology applied to Lexan Exell D and Lexan Exell D ST sheet ensures long-term optical quality under intensive UV exposure, and maintains the superior toughness of the polycarbonate material in comparison with other thermoplastic glazing. Under ISO 4892, a test has been developed using high intensity Xenon lamps to simulate natural sunlight. Together with UV filters and programmable rain cycles, the test is able to simulate natural conditions. Accelerated weathering tests by GE Structured Products using in-house Xenon 1200 apparatus have been carried out according to ISO 4892. However, even tougher demands were placed on the materials by removing the UV filter for 1/6 of the cycle.

Placed within this environment, Lexan Exell D sheet was exposed to 5,000 hours. Experience with the Xenon test equipment indicates this relates to 15 years' natural exposure in a moderate European climate. Following the test, the optical properties of light transmission and yellowness index were measured and compared with an un-aged sample.* Figures 7 and 8 indicate the changes in the values over the simulated 15 year period of Lexan Exell D sheet and Lexan Exell D ST (standard clear grade).

Fig. 7: Decrease of Light Transmission

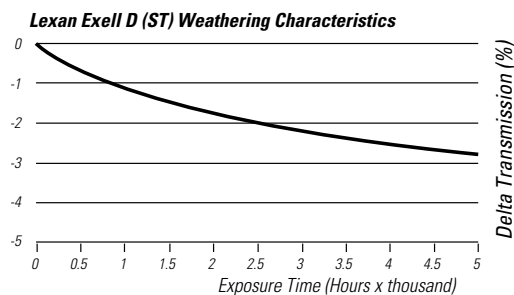
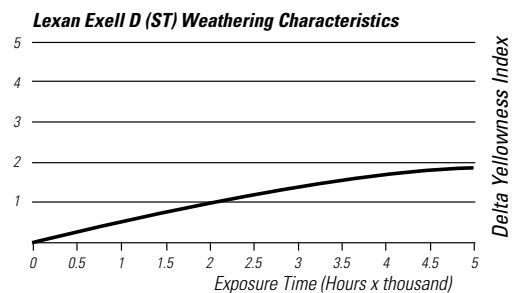

Fig. 8: Delta Yellowness Index (ASTM D1925)



*WARRANTY

GE Plastics offers a Ten Year Limited Warranty on Lexan Exell D and Lexan Exell D ST sheet covering discolouration, loss of light transmission and loss of strength due to weathering. Please consult your local distributor or GE Structured Products Sales Office for specific details.

Solar Heat Gain

Temperature Increase Inside the Building

Solar Control

Transparent grades of Lexan solid sheet have excellent light

transmission of between 75 and 87% depending upon thickness. However, for buildings in hot climates or with south facing aspects, Lexan sheet is available in translucent grades of bronze, grey and opal white. These grades significantly reduce solar heat build-up, helping to maintain comfortable interior temperatures.

The specially tinted sheet cuts down the brightness of sunlight to a pleasing level and reduces air conditioning costs in the summer.

Solar Heat Gain

The solar radiation reaching the sheet is reflected, absorbed and

transmitted, as shown in Figure 9. The greatest proportion is transmitted and the total solar transmission (ST) is the sum of the direct transmission (DT) and the inwardly released part of the absorbed energy (A). Table 3 outlines the overall solar control properties of Lexan solid sheet.

Fig. 9: Solar Energy Transmission

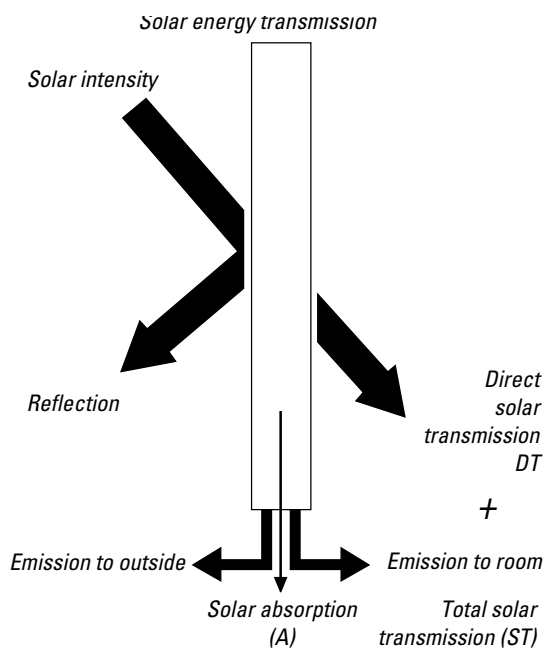

Table 3

	LT	R	A	DT	ST	SC
Lexan solid sheet	Light transmission in %	Solar reflection in %	Solar absorption in %	Direct solar transm. %	Total solar transm. %	Shading coefficient
Transparent 112	87	9	9	82	84	0.97
Bronze 5109	50	7	38	55	65	0.75
Grey 713	50	7	38	55	65	0.75
Opal white 82939	54	20	29	51	58	0.67
Opal white 82943	25	54	18	28	33	0.38

Temperature Resistance

The heat build-up of glazing materials can be seen as a function of the absorption of the glazing

material and the solar intensity.

In countries with intense sun radiation, and when high energy absorbing tinted glazing is installed, heat build-up of the glazing can be considerable. Calculations and actual measurements on installed Lexan sheet in several projects throughout Europe have shown that sheet surface temperatures of 100°C can exist.

Figure 10 gives an example of the heat pattern of an open ventilated horizontal sloped roof glazed with solar bronze tinted Lexan sheet when exposed to intense sunlight.

Fig. 10

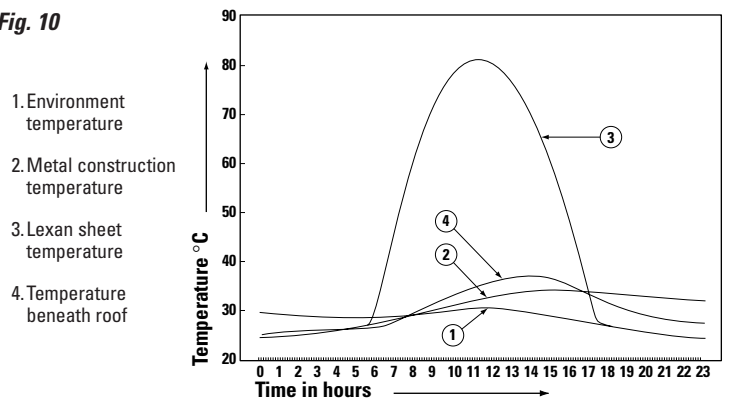

Lexan sheet is characterised by its excellent retention of impact strength and stiffness at elevated temperatures, even over an extended period. Lexan sheet retains 85% of its room temperature flexural modulus at 82°C. The Vicat softening temperature and the Deflection Temperature Under Load of Lexan polycarbonate are both around 140°C. Lexan sheet has a continuous-use temperature of 100°C. At the other end of the scale, the minimum continuous-use temperature has been set at -40°C. Using Lexan at lower temperatures is possible since the embrittlement temperature is as low as -110°C.

UL Ratings

The U.S.A. Underwriters Laboratories' continuous use temperature rating can

be considered as a reliable indicator of a thermoplastic's long-term high temperature performance. The most important properties of the thermoplastic are tested at various temperatures. Test results are extrapolated over a period of 10 years and no property may lose more than 50% of its original value. Table 4 outlines the UL-continuous use temperatures of typical thermoplastic glazing materials.

Table 4; UL Temperature Ratings UL 746B

Lexan Polycarbonate	100°C
Acrylic	50°C
PVC	50°C

Abrasion Resistance

Lexan Margard sheet MR5-E, MRA3 and FMR5-E

High resistance to abrasion

Lexan Margard sheet has a unique, hard surface coating which provides a high level of protection against unsightly scratching. It is therefore ideal for use in applications where frequent contact is likely. The state-of-the-art coating on both surfaces of the Margard sheet makes it one of the most abrasion-resistant plastic safety and security glazing products available.

Table 5: Lexan Margard MR5-E, MRA3 and FMR5-E Abrasion Resistance

	Test Method	Lexan Margard FMR5-E	Lexan Margard MR5-E	Lexan Margard MRA3	Glass
Taber Abrasion* CS10 F Wheels 500 gm weight	ASTM D1044 ANSI 226.1 1983	% Haze	% Haze	% Haze	% Haze
a) 100 cycles	Plastic safety glazing test Extended test	7	2.1	-	0.5
b) 500 cycles		-	4.5	3	1.0
c) 1000 cycles		-	12	-	2.0
Sandrieseel Test	Glass safety glazing test DIN 52348	3	2.0	-	1.0

*Average values

Mutual benefits of Lexan Margard MR5-E, MRA3 and FMR5-E

• UV protection

Whilst the coating of Lexan Margard is essentially an abrasion-resistant barrier, the proprietary technology also offers improved UV protection.

MRA3 is not UV protected

• High resistance to chemicals

Lexan Margard sheet is immune to contact with many chemicals such as cleaning fluids, paints and adhesives. Its unique surface coating also resists graffiti, enabling easy restoration to a 'good as new' condition.

• Comprehensive warranty*

Lexan Margard sheet is backed by a five years limited warranty* against loss of light transmission and coating failure, and by a ten years warranty* against breakage.

* See Warranty for exact details.

Lexan Margard MR5-E and MRA3

• Flat applications only

Due to its mar-resistant coating, Lexan Margard MR5-E/MRA3 sheet cannot be cold-formed. The sheet is intended for flat applications only.

• Anti-vandal glazing

Glazing with Lexan Margard sheet is the ideal solution in areas where there may be a risk of vandalism.

• Security glazing

Lexan Margard sheet will prevent a burglar from forcing an entry.

• Safety screens and acoustic screens

Lexan Margard sheet is the ideal material for safety screening in sports stadia and other outdoor applications.

MRA3 only suitable for indoor applications.

• Premises safety glazing

Lexan Margard sheet will not shatter or splinter, so greatly reducing the risk of accidental injury in applications like interior partitions, doors and machineguards.

Lexan Margard Sheet FMR5-E (Formable)

Curved applications

Design freedom, light weight and optical clarity combined with superior mechanical properties make Lexan Margard FMR5-E the ideal glazing material for shaped applications like: curved windows (e.g. revolving doors), partitions, skylights, barrel vaults, balcony glazing, stair glazing, shelters and safety guards.

Sound and Thermal Properties

Sound reduction

Single Glazing

Installing Lexan solid sheet into single or double glazing systems, meets the acoustic requirements of today's glazing. Table 6 compares single glazed Lexan solid sheet's performance with that of glass.

Table 6: Acoustic insulation DIN 52210-75 R_w (dB)

Thickness in mm	Lexan solid sheet	Glass
4	27	30
5	28	30
6	29	31
8	31	32
9,5	32	33
12	34	34

Double Glazing

When applied together with existing glass and an airspace of >50 mm, Lexan solid sheet considerably reduces sound transmission, particularly at low frequencies, such as traffic noise.

Table 7: DIN 52210-100 Acoustic Insulation

Sheet thickness in mm			
Lexan solid sheet	Glass	Air Space in mm	R _w in dB
4	6	85	39
6	6	85	40
8	6	85	42
9.5	6	85	44
4	6	54	36
6	6	54	37
8	6	54	39
9.5	6	54	41

Thermal Insulation

Energy Loss Calculation

The need to reduce energy consumption, and therefore energy costs, is one of the highest priorities in any business today. Substantial savings in excess of 20% are possible when installing Lexan solid sheet instead of mono-layer glass. When calculating according to the guidelines laid out in DIN Standard 4701, an average annual saving of between 0.9–1.3 litres of oil or 1.0–1.5 m³ of gas per m² of glazing area will be obtained by decreasing the K-value by 0.1 W/m²K.

Single Glazing

When using Lexan solid sheet, considerable energy cost savings can be achieved by preventing excessive heat loss in winter and heat entry in summer. Heat loss is normally

recorded as a K-value, which is the amount of energy transmitted through a material per square metre of glazing area and per degree of temperature difference.

Table 8: Single Glazing K-values W/m²K

Thickness in mm	Lexan Solid Sheet	Glass
4.0	5.33	5.82
5.0	5.21	5.80
6.0	5.09	5.77
8.0	4.84	5.71
9.5	4.69	5.68
12.0	4.35	5.58

Double Glazing

The selection of Lexan Exell D or Margard as either internal or external secondary glazing will depend upon the specific requirements of the building. Internal or external secondary glazing can improve protection against burglary. External installation can protect against vandalism. For effective insulation, the best results are obtained by leaving a 20–60 mm space between the existing glazing and the Lexan Exell D, Lexan 9030 or Margard overglazing. Table 9 shows the K-value as a function of different Lexan solid sheet thicknesses in combination with different glass thicknesses.

Table 9: Double Glazing

Thickness Glass in mm	Thickness Lexan solid sheet in mm	Air Space in mm	K-values W/m ² K
4	4	20-60	2.77
4	5	20-60	2.73
5	5	20-60	2.72
4	6	20-60	2.70
6	6	20-60	2.68
5	8	20-60	2.62
6	8	20-60	2.60
6	9.5	20-60	2.56
6	12	20-60	2.54

Triple Glazing

Extremely low K-values can be obtained by overglazing Lexan Exell D, Margard or Lexan 9030 in combination with double sealed glass units.

Table 10: Triple Glazing

*Thickness sealed glass unit in mm	Thickness Lexan solid sheet in mm	Air Space in mm	K-values W/m ² K
4+4	5	30-60	1.85
6+4	6	30-60	1.82
8+4	8	30-60	1.78

*air space = 12 mm

Note: For overglazing fixing details see page 20

Miscellaneous Properties

Light Weight

Lexan polycarbonate sheet products are ideal replacements for more traditional glazing materials. They are safe and easy to handle, cut and install and are virtually unbreakable. Their light weight offers significant cost savings in transportation, handling and installation; when compared with glass of the same thickness they offer a weight saving of more than 50%.

Table 11: Weight comparison in kg./m²

Thickness	Lexan Sheet	Glass
3	3.60	7.50
4	4.80	10.00
5	6.00	12.50
6	7.20	15.00
8	9.60	20.00
9.5	11.40	23.80
12	14.40	30.00

Fire Performance

Fire Performance

Lexan solid sheet has good fire behaviour characteristics, and receives high ratings in several major European fire performance tests. As a thermoplastic, Lexan solid sheet will melt under the intense heat of a fire. However, it will make almost no contribution to the growth of a fire through flame spread.

The base raw material has an LOI (Limiting Oxygen Index) of 25 and does not contain additional flame retardant additives. The LOI (ISO 4589 ASTM D2863) is defined as the minimum oxygen concentration in which the material will burn for three minutes or can keep the sample burning over a distance of 50 mm. The higher the LOI value, the less the likelihood of ignition.

Large-scale roof test

When exposed to heat, the Lexan solid sheet will soften at 150°–160°C.

This creates a hole in the sheet which allows smoke and heat to escape and reduces the temperature to around 60°C. (A reference report is available upon request). Provided there is enough room to cool down and fall away from the heat source, any droplets of molten Lexan sheet will solidify and self-extinguish. Therefore no propagation of fire takes place. Most test devices are designed in such a way that, because burner and the space measured between the test specimen is so short, solidification and the extinguishing of flames is sometimes not observed.

National Standards

In Germany the recognized practice for

building is to measure according to DIN 4102 "fire performance of building materials". Thermoplastics are measured according to B1 (combustible, low flammability) via the "Brandschacht test" and according to B2 (combustible, moderate flammability) via the small burner test.

In France the classification of the fire performance of building materials ranges from M0 (non-combustible) to M4 (highly flammable). The espiateur test (NF P92-501) is the method of determining the fire performance of rigid samples. M1 is achieved when the specimen burns ≤ 5 seconds.

In the UK, the performance of plastics is tested according to BS 476 part 6 fire propagation and part 7 surface spread of flame. For part 7, classification ranges from class 1 (best) to class 4 (worst). A "Y" simply means melting behaviour was observed.

Chemical Resistance

Chemical Resistance

Lexan sheet is successfully used in combination with many building materials and glazing compounds. Taking into account the complexity of chemical compatibility, all chemicals which come into contact with polycarbonate should always be tested. For sheet products, the most common materials are sealants, gaskets and the various cleaning media. Chemical compatibility testing is an ongoing process at GE Structured Products and many standard products have already been tested. A complete list of recommended cleaners, gaskets and sealants is available on request. However, a shortened list of some of the more common compounds is shown below and overleaf.

When using glazing compounds it is essential that the sealant system accepts a certain amount of movement to allow for thermal expansion, without loss of adhesion to the frame or sheet. GE Silicone sealants are generally recommended for use with Lexan sheet, as shown in Table 14. It is strongly advised when using non GE Bayer Silicones sealing compounds to check compatibility before use.

Chemical Resistance of Lexan Margard

The "mar" resistant coating of Lexan Margard provides an additional benefit in terms of chemical resistance.

The proprietary coating is resistant to a range of chemicals that under normal circumstances is detrimental to Lexan polycarbonate.

Table 14: Recommended Sealants

Sealant	Supplier
Silpruf® MultiSil®	GE Bayer Silicones GE Bayer Silicones

Do Not use PVC gaskets

Due to the migration of additives from soft PVC, the Lexan sheet can be chemically affected resulting in surface cracks or even sheet breakage.

Compatible Neoprene, EPT or EPDM rubbers with an approximate Shore Hardness of A65 are recommended. Compatibility reports for different rubber types are available upon request.

Table 15: Recommended Gasket Systems

Gasket Type	Supplier
EPDM R27* Chloropene, RZ4-35-81	Helvoet
EPDM 4330, 4431, 5530, 5331	Vredestein
EPDM 3300/670, 64470	Phoenix
*more grades available	

In case of doubt about any aspect of the chemical compatibility of the Lexan sheet range, always consult your nearest GE Structured Products Sales Office for further advice.

Cleaning

Cleaning

Periodic cleaning using correct procedures with compatible household cleaners is recommended to prolong service life. For general cleaning, it is recommended that the following instructions are adhered to.

Table 16: Recommended Solvent Cleaners

Cleaner/Solvent	Supplier
White Spirit	various
Petroleum Ether (BP65°)	various
Hexane	various
Heptane	various

Procedure 1 - Small Areas

1. Rinse sheet with lukewarm water.
2. Wash sheet with a solution of mild soap or household detergent and lukewarm water, using a soft cloth or sponge to loosen any dirt and grime.
3. Rinse with cold water and dry with a soft cloth to prevent water spotting.

Procedure 2 - Large Areas

1. Clean surface with a high pressure water and/or steam cleaner.
2. Use of additives to the water should be restricted to those compatible with Lexan sheet.

Table 17: General purpose cleaners

Supplier	Product	Application method
Nilco Chemical Company Ltd	Anglian windows glass cleaner	hand/high-pressure spraying
Marollaud sa	Oloram DTU 5216	hand/high-pressure
Johnson Wax	123 Emerel 7% Jonclean 111 1% Jonclean 112 2%	hand/cloth hand/cloth high pressure
Applied Chemicals Ltd	Heavy Duty Pres. washing det. 2%	high pressure
Witty Chemie	Witty Pool red SE Witty Pool red HR	cloth cloth
Glass Renovation Services Ltd	Glass cleaner 366	hand/high-pressure
AVO Chem. Tech. Ind. bv	Taski Swissan, 1% Taski R 50, 5% Taski Calcadid, 10%	spraying/cloth machine spraying

Recommended Cleaner Supplies

DiverseyLever Divizia
Odborárska 52
SK-831 02 Bratislava
Slovakia
Ph: 07 - 501 29 88/
Ph: 07 - 525 48 95

DiverseyLever
Haachttesteenweg 672
B-1910 Kampenhout
Belgium
Ph: 016 - 61 77 77

DiverseyLever AG
CH-9542 Münchwilen
Switzerland
Ph: 071 - 969 27 27

DiverseyLever
Wienerbergstrasse 7
A-1103 Vienne
Austria
Ph: 01 - 60 55 70

DiverseyLever SRO
Táborská 5/979
140 00 Praha 4
Czech Republic
Ph: 02 - 61 22 25 24

DiverseyLever A/S
Smedeholm 3-5
DK-2730 Herlev
Denmark
Ph: 044 - 85 61 00

DiverseyLever France
9-11, Avenue du Val de Fontanay
94133 Fontanay Sous Bois
France
Ph: 01 - 45 14 76 76

DiverseyLever (Offices)
Via Meucci 40
20128 Milan
Italy
Ph: 022 - 670 24 32

DiverseyLever Sp. z.o.o.
Ul Zupnica 17
03-821 Warsaw
Poland
Ph: 022 - 670 24 32

DiverseyLever
Rautatienkarn 9-11
FIN-20200 Turku
Finland
Ph: 02 - 269 72 22

DiverseyLever AB
Röntgenvägen 3
S-14152 Huddinge
Sweden
Ph: 08 - 779 93 00

DiverseyLever
Jamestown Road
Finglas
Dyblin 11
Ireland
Ph: 08 - 779 93 00

DiverseyLever
Calle Rosselon 174-176
08036 Barcelona
Spain
Ph: 93 - 323 10 54

DiverseyLever
General Offices
Weston Favell Centre
Northampton NN3 8 PD
United Kingdom
Ph: 01604 - 40 53 11

DiverseyLever
Mallaustrasse 50-56
Postfach 81 03 60
D-68 219 Mannheim
Germany
Ph: 0621 - 875 70

DiverseyLever
Maarssebroekseweg 2
3606 AN Maarsse
Netherlands
Ph: 030 - 247 69 11

Web page:
www.diverseylever.com

Recommended cleaners

SUMALIGHT D12

BRUCODECID

(heavy duty cleaner
i.e. Railwaystations)

Points to remember



- **Don't use abrasive or highly alkaline cleaners.**
- **Never scrape the sheet with squeegees, razor blades or other sharp instruments.**
- **Don't clean Lexan® sheet products in the hot sun or at elevated temperatures as this can lead to staining.**

Cleaning

Recommendations for Cleaning Lexan Margard

The unique surface of Lexan Margard sheet provides superior protection against chemical attack. Even graffiti, such as spray paint, are easily and quickly removed. However, because of this material's mar resistant coating, the use of abrasive cleaners and/or cleaning implements that may damage or scratch the coating should be avoided.

The recommended cleaning procedure for the removal of graffiti, etc., is as follows:

- Paints, marking pens, inks, lipstick, etc. use graffiti remover.
- Labels, stickers use kerosene or white spirit.
- Final wash with warm soap solution, followed by rinse with clean water.

Table 18: Recommended Graffiti Removers

Supplier	Product	Application
Chemalex	Vandalex	Spray/hand
Nucoat	AG 2	Hand/cloth
Prochemko	Graffitex III	Hand/cloth
Jumbo	J.T. Graffiti	Spray/hand/cloth

Table 19: Cleaner + Graffiti remover suppliers

<p>Nilco Chemical company Ltd Steward Road Basingstoke, Hampshire RG24 06X UK Ph: 0256 - 474661 Fax: 0256 - 50603</p> <p>Johnson Wax P.O. Box 22 3640 AA Mijdrecht The Netherlands Ph: 02979 - 83800 Fax: 02979 - 83831</p> <p>Witty Chemie Herrenrothstrasse 12 - 16 8901 Dinkelscherben Germany Ph: 08292 - 1044 Fax: 08292 - 1090</p> <p>AVO Chem. Tech. Ind bv P.O. Box 455 6710 BL Ede The Netherlands Ph: 08380 - 30255 Fax: 08380 - 21248</p> <p>Nucoat Dudley road Wolverhampton UK Ph: 0902 - 336565 Fax: 0902 - 337351</p> <p>Jumbo Totaal bv Achterzeedijk 57 2992 SB Barendrecht The Netherlands Ph: 01806 - 19009 Fax: 01806 - 19473</p>	<p>Marollaud sa BP7 Rue de la Gatine 7940 Courlay France Ph: 0722324</p> <p>Applied Chemicals Ltd. Wilsons Lane Coventry, Warwickshire, CV6 6JA UK Ph: 0203 - 363575</p> <p>Glass Renovation Services Ltd. 1 Bromley Lane, Chislehurst Kent BR7 6LH UK Ph: 01 - 4670267 Fax: 01 - 4670950</p> <p>Chemalex 432 Hillington Road Glasgow 952 4BL UK Ph: 041 - 882 - 9938 Fax: 041 - 810 - 5163</p> <p>Prochemko Int. bv P.O. Box 60 3770 AB De Bilt The Netherlands Ph: 030 - 432410 Fax: 030 - 435157</p>
---	--

General Guide-lines

Storage

Lexan solid sheet should be stored and protected against atmospheric influence like sun, rain, etc. Lexan solid sheets of the same length should be stacked together horizontally or, if different lengths, graded with the longest sheet at the bottom of the stack in order to avoid unsupported overhangs. Do not stack where they can be walked on or driven into.

Fig. 15

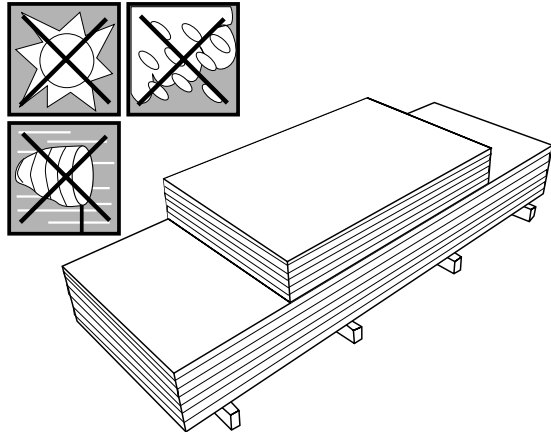

Handling

As with all glazing materials, care should be exercised when handling and transporting Lexan sheet in order to prevent scratches and damage to sheet edges. Each sheet is packaged to minimise the risk of these problems.

Cutting and Sawing

Lexan polycarbonate sheet products can be cut and sawn easily and accurately using standard workshop equipment.

General guide-lines are listed below with specific recommendations outlined in each cutting section.

- The sheet must always be securely clamped to avoid undesirable vibration and roughly cut edges.
- All tools should be set for cutting plastics with fine toothed panel blades.
- The protective masking should be left on the sheet to prevent scratching and other surface damage.
- When finished the edges of all Lexan sheet products should be clean and free of notches.
- If possible swarf and dust build-up should be blown away with a compressed air supply.

Circular Saws

This type of cutting operation is the most common and, whilst cutting speeds and feeds are not so critical as with other thermoplastics, it is important to follow the recommended guide-lines.

- Always use a low feed to get a clean cut.
- Always start cutting with the blade at full speed.
- For single sheets less than 3 mm thick, bandsaws or jig saws are preferred to circular saws.

Bandsaws

These can be of the conventional vertical type or the specially developed horizontal type suitable for plastic sheet materials. In both cases it is vital that the sheet is adequately supported and clamped during the cutting operation. The saw guides should be as close to the sheet as possible to reduce blade twist and off-line cutting.

Jig Saws and Hacksaws

The most important consideration with this type of cutting is support and clamping, particularly when using a jig saw. Blades with a tooth spacing of 2–2.5 mm are ideal and low cutting feeds are recommended.

Drilling

Standard high speed steel twist drills or drills with an angular wedged bit can be used for drilling Lexan sheet products. Carbide-tipped drills can also be used since they retain their sharp cutting edge.

The most important factor to consider when drilling Lexan sheet products is the heat generated during the actual process. In order to produce a clean, well-finished hole that is stress-free, the heat generated must be kept to an absolute minimum.

By following a few basic guide-lines, clean, stress-free holes can be produced easily.

- The drill hole must be cleared frequently to prevent swarf build-up and excessive frictional heat.
- The drill must be raised from the hole frequently and cooled with compressed air.
- The sheet or product must be adequately clamped and supported to reduce vibration and ensure a correctly sized hole.
- Holes should not be drilled closer to the edge of the sheet than two times the diameter of the hole.
- All holes must be larger than the bolt, screw or fixing to allow for thermal expansion and contraction.

Wind and Snow Loading

Dynamic Wind Pressure

The wind speed is used to determine the actual loading upon the glazing panels. In mathematical terms, the pressure loading is calculated by multiplying the square of the design wind speed by 0.613.

$$q = KV^2$$

where:

q = dynamic wind pressure in N/m^2

$K = 0.613$

V = design wind speed in metres/second

Table 20: Values of q in SI units (N/m^2)

Wind speed m/s	Wind pressure N/m^2	Wind speed m/s	Wind pressure N/m^2
10	61	40	981
15	138	45	1240
20	245	50	1530
25	383	55	1850
30	552	60	2210
35	751	65	2590

For glazing projects with an unusual loading condition, please contact your local GE Structured Products Sales Office.

Pressure Coefficient

To allow for local fluctuations in the acceleration/ deceleration of the wind by building or glazing geometry, it is necessary to include an appropriate pressure coefficient. The wind loading is obtained by multiplying the dynamic wind pressure by the pressure coefficient. Detailed pressure coefficient values can be found in the appropriate building norms.

Snow Loading

Snow loading on roof glazings can be considered equivalent to a vertically, uniformly distributed load, acting per m^2 of the horizontal projection of the glazing. Snow loading factors can be obtained from the appropriate building norm.

Computer Aided Sheet Engineering

A computer aided design programme has been developed especially for large glazing projects, or projects with an uncommon shape or unusual loading conditions. The programme creates the finite element model of a particular glazing design, applies the specified loads and edge conditions and runs the deflection analysis. Consult your nearest GE Structured Products Technical Service Centre for further advice.

Fig. 16

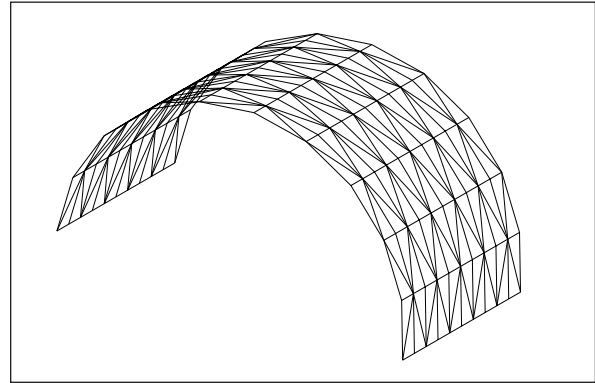

Finite element model

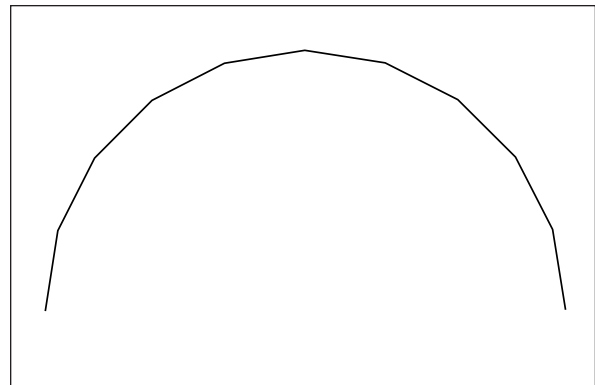

Deflection plot

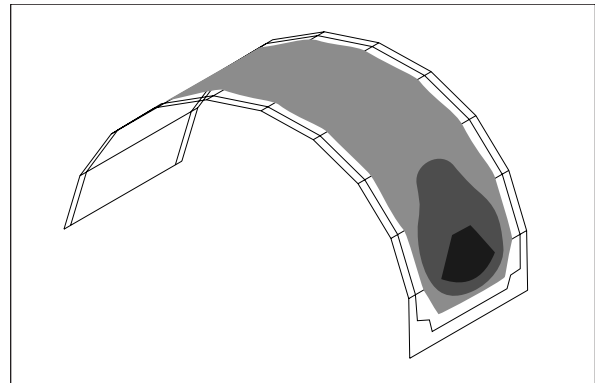

Deflection contour plot

Wind and Snow Load Consideration

The results shown in Tables 23, 24–28 are applicable for loads varying from 600 up to 2000 N/m^2 . These loads cover most of the normal glazing projects fulfilling requirements according to European standards BSI - CPS chapter V part 1, NEN 3850 and DIN 1055.

Installation

Glazing Precautions

- Glazing of Lexan sheet should be considered a finishing operation and should be scheduled as a final step in the completion of a building.
- Care should be taken to avoid surface marring during storage, cutting, transporting and installation.
- After installation and removal of masking, Lexan sheet should be protected from paint, plaster and other contamination by polyethylene or other covering taped to the framing members.
- Check compatibility of the Lexan sheet with the suppliers of the selected glazing tapes, gaskets and sealants.

Thermal Expansion Allowance

Since Lexan sheet has a larger coefficient of linear thermal expansion than that of the glazing profiles commonly used, care should be taken to allow free expansion of the sheet to avoid bowing and thermal stress. Linear Thermal Expansion Coefficients for various materials are shown below:

Table 21

Material	m/m°C x 10 ⁻⁵
Lexan sheet	6.7
Glass	0.7 - 0.9
Aluminium	21 - 2.3
Steel	1.2 - 1.5

Allowance for thermal expansion must be made for both the length and the width of the Lexan sheet. The recommended allowances for various sheet dimensions are outlined in Table 22.

In general: Thermal expansion of the sheet is approximately 3 mm per linear metre.

Sheet Edge Engagement/Rebate Depth Requirements

The rebate depth is the sum of the specific edge engagement and the expansion allowance. The total rebate depth should include a minimum edge engagement and an allowance for thermal expansion.

Table 22 indicates the minimum required sheet edge engagement of Lexan sheet in the glazing profiles.

Fig. 17

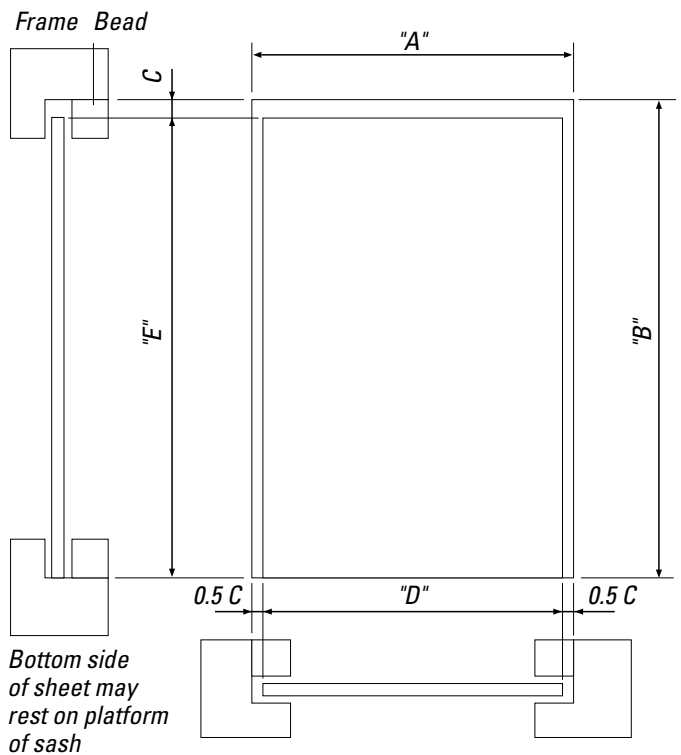
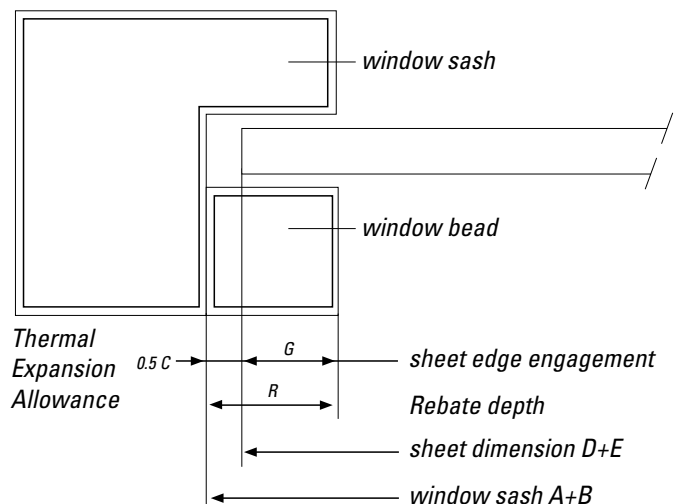

Table 22: Thermal Expansion/Sheet edge engagement

Sash Dimensions (A-B) (mm)	Trim Sheet by C (mm)	Sheet edge engagement G (mm)
300	1	6
300 - 600	1 - 2	6 - 9
600 - 900	2 - 3	9 - 12
900 - 1200	3 - 4	12 - 15
1200 - 1500	4 - 5	15 - 18
1500 - 1800	5 - 6	18 - 20
1800 - 2100	6 - 7	20
2100 - 2400	7 - 8	20
2400 - 2700	8 - 9	20
2700 - 3000	9 - 10	20

For window sizes exceeding 2000 mm, sheet edge engagement of around 20 mm is sufficient

Fig. 18



Flat Glazing Installation

Glazing Systems Figures 19 and 20 illustrate typical installations for dry and wet glazing systems using Lexan polycarbonate sheet products.

It is extremely important when installing Lexan sheet that the edges are correctly clamped, whether the application involves wet or dry glazing conditions.

See page 17 for thermal expansion clearance and minimal sheet edge engagement.

Wet Glazing Systems Lexan sheet can be glazed using standard metal or wooden window frames in combination with glazing tapes and non-hardening glazing compounds. Polybutylene glazing filler tapes are suitable.

When using glazing compounds it is essential that the sealant system accepts a certain amount of movement, to allow for thermal expansion, without loss of adhesion to the frame or sheet. Silicone sealants are generally recommended for use with Lexan sheet, but it is strongly advised when using sealing compounds to check compatibility before use.

Care should be taken not to use Amine nor Benzamide curing silicone sealants, which are not compatible with Lexan sheet and result in crazing, particularly when stress is involved. See page 13 for suitable sealants.

Dry Glazing Systems The advantage of dry glazing is that the rubber gaskets snap-fit into the glazing bars which allows free movement of the sheet during expansion and contraction. This should be considered therefore for both aesthetic reasons and for applications where sheet expansion exceeds sealant limitations. Neoprene, EPT or EPDM rubbers, ± 65 shore, are recommended.

Fig. 19

Dry glazing installation

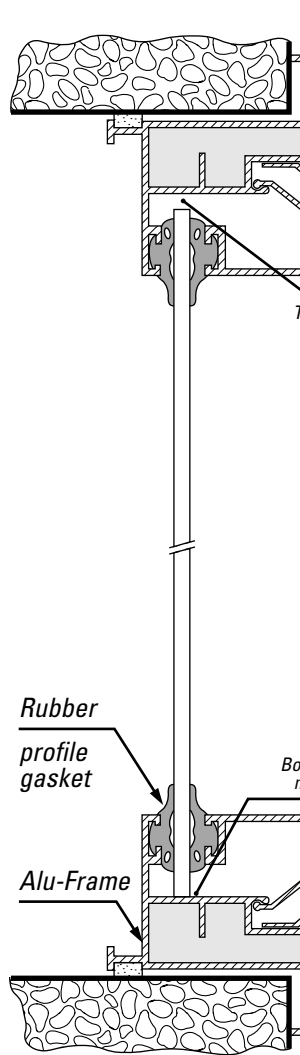
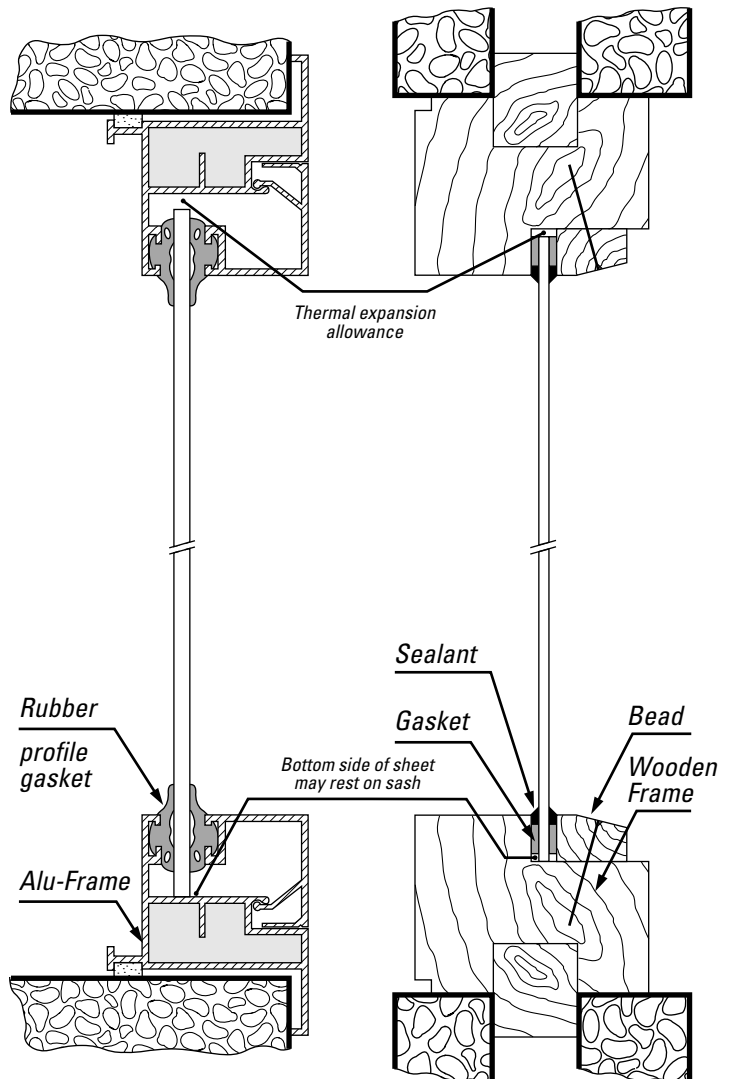

Fig. 20

Wet glazing installation



Sheet Glazing Guide-lines

Wet Glazing

Fig. 21

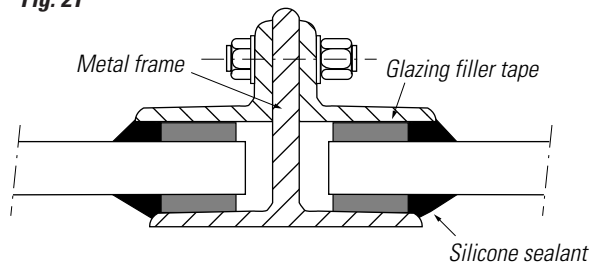

Dry Glazing

Fig. 22

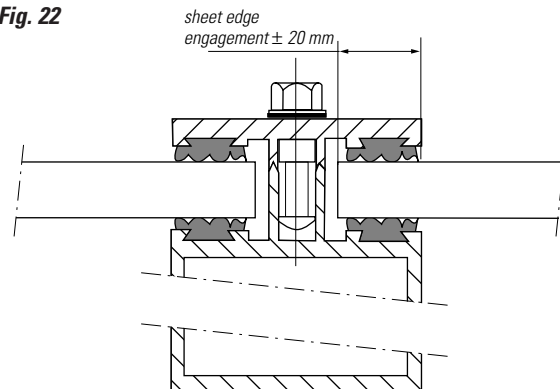

Do's

- Clean the window frame. Remove old putty or broken glass, if necessary.
- Measure the sheet edge engagement area and internal window frame dimensions, i.e. the space into which the Lexan sheet will be fitted.
- Calculate the sheet size, allowing clearance for thermal expansion (3 mm per linear metre).
- Select the right thickness to fulfil loading requirements. (See Tables 23 and 24)
- Clamp the Lexan sheet to a support table to avoid vibration and rough cutting.
- Cut the sheet to the required size, using a standard electric circular or jig saw.
- Remove any sharp edges and irregularities from the sheet.
- Peel back approximately 50 mm of the masking film from all edges of the cut sheet on both sides.
- For wet glazing, apply single-sided self-adhesive glazing tape or rubber profile to both the window frame and the bead.
- For dry glazing, snap-fit compatible neoprene rubber gaskets in place in the support profile as well as in the clamping cover profile.
- Insert the Lexan sheet into the window frame.
- Fix the window bead or the clamping cover profile in place.
- For wet glazing, apply an approved silicone sealing compound, such as Silglaze/Silpruf between the sheet and the window frame/bead.
- Remove all masking film immediately after installation.
- Clean the window carefully with warm soapy water and with a soft cellulose sponge or woollen cloth.

Don'ts

- Do not use plasticised PVC or incompatible rubber sealing tapes or gaskets.
- Do not use Amine, Benzamide or Methoxy based sealants.
- Do not use abrasive or highly alkaline cleaners.
- Never scrape Lexan sheet with squeegees, razor blades or other sharp instruments.
- Do not walk on Lexan sheet at any time.
- Do not clean Lexan sheet in hot sun or at elevated temperatures.
- Benzene, gasoline, acetone, carbon tetrachloride or butyl cellosolve should never be used on Lexan sheet.

Flat Glazing Installation

Overglazing Double Glazing

The selection of Lexan 9030, Exell D or Lexan Margard sheet as either internal or external

secondary glazing will depend upon the specific requirements of the building: external or internal secondary glazing for improved burglar resistance and externally for protection against vandalism.

Specialised companies, recognising the need for more substantial and secure overglazing designs, have developed pre-assembled profile systems. These systems allow for easy pre-fabrication and the rubber gaskets are interchangeable to hold sheet thicknesses of between 5–10 mm.

Figures 23 and 24 show typical examples of overglazing installations.

Internal Overglazing

Lexan Margard sheet is also an ideal glazing material for interior applications, (Figure 23).

When Lexan Margard sheet is installed internally, the criteria for deflection under wind load (as indicated in Table 23) no longer apply and therefore the recommended sheet thickness can be reduced.

Fig. 23: Internal Overglazing

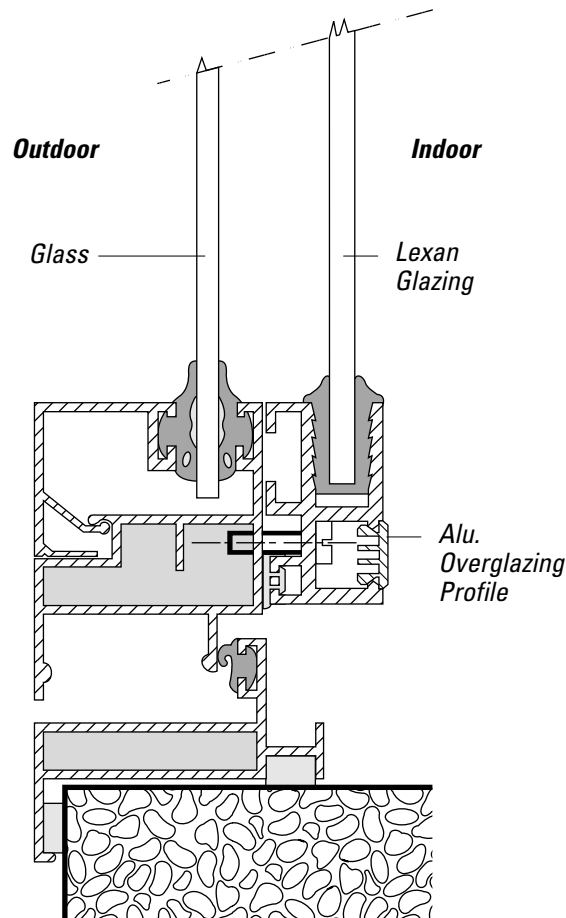

External Overglazing

Depending upon requirements, either Lexan Margard or Lexan Exell D can be used

(Figure 24). Taking into account the functional and aesthetic requirements with respect to deflection under wind load, the sheet thickness recommendations given in Table 23 are suitable.

Fig. 24: External Overglazing

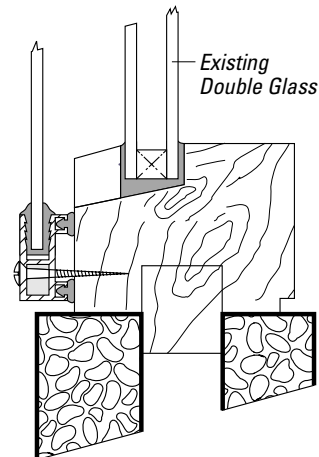

Double Glazing Units

Due to the water vapour permeability of Lexan sheet, condensation in the cavity using either

Lexan/Lexan or Lexan/glass sealed units is not inconceivable. Permanent condensation inside the cavity may occasionally be a problem and algae growth in the form of green deposit can occur. There is a technique that can be adopted to significantly reduce the condensation. U-shaped aluminium distance holders ± 20 mm can be used to create an airgap. Holes of 6 mm diameter c.t.c. ± 200 mm should be drilled in the aluminium U profile used for the bottom of the glazing.

These venting holes allow for some air ventilation and prevent excessive condensation through drainage to the outside. To avoid dust/insect penetration, the holes inside the cavity must be sealed with a perforated filter tape such as Multifoil AD 3429. To seal the Lexan sheet onto the alu spacer, silicone sealant can be used. Care should be taken to provide clearance between both the sheet edge and the sash platform to allow for condensation drainage. These guide-lines are recommendations only. No guarantee can be given since the above mentioned problems depend largely on the prevailing environmental conditions.

Fig. 25

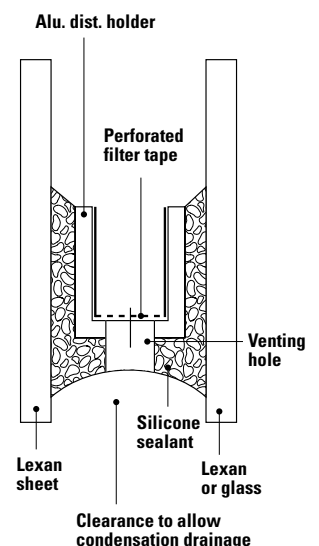

Flat Glazing Sheet Thickness Selection

Four sides clamped Lexan sheet

The deflection characteristics in this particular configuration are dependent upon the ratio of the support bar spacing a:b, (see Figure 26).

In practice "a" represents the centre to centre distance of glazing profiles on the short glazing side i.e. the width of sheet.

"b" represents the centre to centre distance of glazing profiles on the long glazing side i.e. length of sheet.

Table 23 indicates the maximum allowable short glazing side of three different ratios of glazing bar spacing.

Ratio sheet width "a": sheet length "b" 1:>2

Ratio sheet width "a": sheet length "b" 1:2

Ratio sheet width "a": sheet length "b" 1:1

The chart assumes an edge engagement as indicated in Table 22, page 17, on all four edges.

Safety Factor

Tables 23 and 24 indicate the maximum allowable sheet sizes at a specified loading which results in an acceptable sheet deflection behaviour without the risk of sheet buckling or pop-out effect.

To calculate the allowable deflection, divide the shortest sheet side "a" by 20. A maximum deflection of 50 mm is recommended.

Example I

Window size: Width: 1600 mm Length: 3200 mm

Ratio a:b = 1:2

Loading: 1000 N/m²

Required sheet type: 12 mm

Maximum deflection: 50 mm

Example II

Window size: Width: 1000 mm Length: 4000 mm

Ratio a:b = 1:>2

Loading: 800 N/m²

Required sheet type: 8 mm

Maximum deflection: 50 mm

Fig. 26

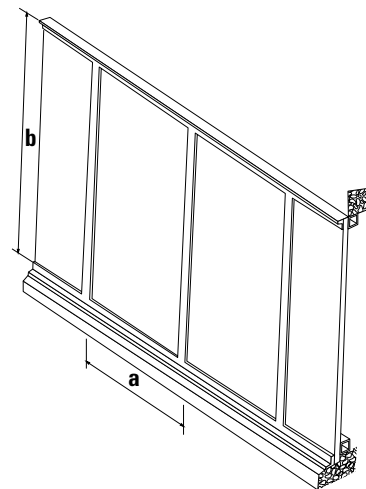

Table 23: Centre to centre distance of glazing profiles (shortest side a)

Lexan sheet thickness in mm	Ratio sheet width: sheet length																							
	1:1	1:2	1:>2	1:1	1:2	1:>2	1:1	1:2	1:>2	1:1	1:2	1:>2	1:1	1:2	1:>2	1:1	1:1,5	1:>1,5	1:1	1:2	1:>2	1:1	1:2	1:>2
3	775	600	400	700	550	375	650	500	--	600	450	--	575	400	--	550	--	--	525	--	--	500	--	--
4	1050	800	550	950	700	490	875	650	450	825	600	425	780	550	400	740	500	--	710	475	--	685	450	--
5	1300	975	675	1180	875	625	1100	800	575	1025	750	550	975	700	510	930	670	490	900	625	470	875	560	450
6	1475	1150	800	1375	1010	725	1300	960	680	1225	900	650	1175	850	600	1125	800	575	1075	710	550	1025	650	525
8	1850	1450	1150	1700	1350	1000	1600	1275	925	1525	1200	860	1475	1150	810	1425	1075	775	1375	1000	750	1325	950	725
9,5	2050	1600	1300	1950	1475	1150	1850	1400	1075	1750	1350	1025	1675	1300	975	1625	1250	925	1575	200	880	1525	1100	850
12	2050	1750	1500	2050	1700	1400	2050	1600	1325	2050	1525	1275	2000	1475	1225	1950	1450	1175	1875	1400	1125	1800	1350	1075
Loading in N/m ²	600			800			1000			1200			1400			1600			1800			2000		

Flat Glazing Sheet Thickness Selection

Two sides clamped Lexan sheet

a = centre to centre distance of glazing profiles
b = sheet length

The major factor determining the sheet deflection behaviour is the distance "a" between the centre points of two adjacent supports. Since any length of sheet can be selected, the measurement "b" does not influence the overall deflection performance.

General Comments

For sloped glazing applications a minimum slope of 5° (9 cm/m sheet length) is advised to allow for rain-water drainage).

Fig. 27

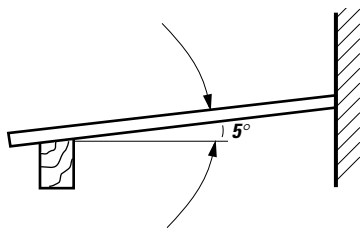

Table 24 assumes an edge engagement as indicated in Table 22, page 17, on both edges.

Two sides bolted Lexan sheet

Fastening Lexan sheet to the intermediate purlins using conventional nuts, bolts and washers is possible. However, all joints and clamping areas require support in the form of compatible rubber washers to distribute the clamping force over as wide an area as possible.

Large metal washers laminated with compatible rubber should be used. Bolts should not be tightened so that the force permanently deforms the sheet or restricts its natural expansion and contraction.

When using any type of bolt assembly it is important to remember that the spacing between the hole and the sheet edge should be at least two times the hole diameter. To calculate the allowable deflection for both glazings, divide the unclamped sheet side "a" by 20. A maximum deflection of 50 mm is recommended.

Site Safety

On roof constructions Lexan sheet should not be used to support a person's weight during installation or cleaning. A temporary wooden beam or other device, supported by the roof members, should always be used.

Fig 28

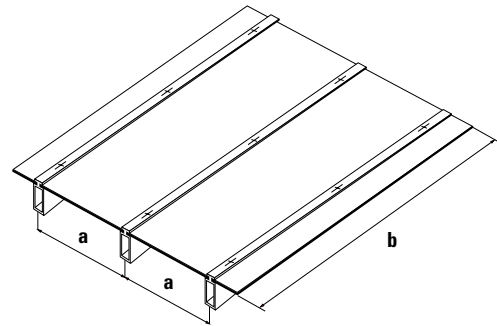

Fig 29

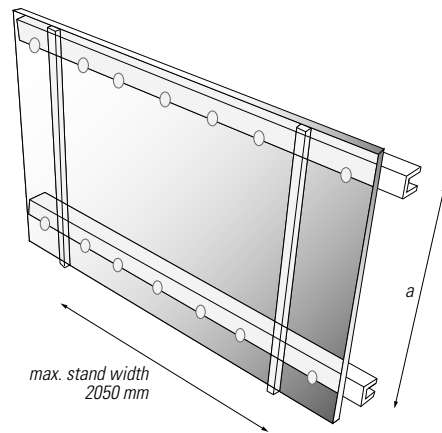

Fig 30

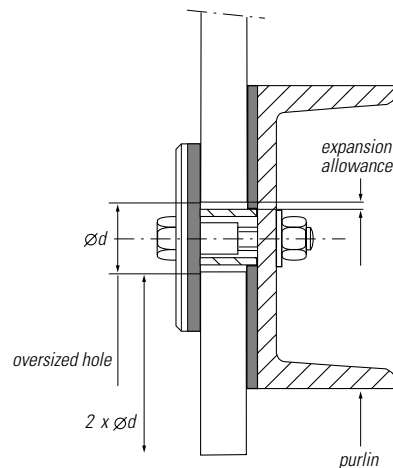

Table 24

Lexan sheet thickness mm	Centre to centre distance glazing profiles "a"							
	400	375	425	400	375	450	430	420
3	550	480	525	495	470	540	510	500
4	620	565	625	595	560	720	690	660
5	750	675	840	790	750	850	820	790
6	1000	900	1000	930	890	1075	1030	1000
8	1200	1075	1250	1190	1125			
9.5	1425	1325						
12								
Loading in N/m²	600	800	1000	1200	1400	1600	1800	≥2000

Curved Glazing Installation

With the exception of Lexan Margard MR5-E, all Lexan sheet can be successfully cold-curved over curved support glazing profiles, to suit many glazing applications, e.g. domes, roof-lights, etc. Providing the radius is not below the minimum recommended value, then the introduced stress by cold-curved will not have any adverse effect upon the mechanical performance of the sheet. Sheets must always be bent longitudinally, never across the width of the sheet.

The minimum radius values are outlined below.

Table 25

Lexan 9030 thickness in mm	Minimum allowable radius in mm
3	300
4	400
5	500
6	600
8	800

Table 26

Lexan Exell D and Lexan Exell D ST thickness in mm	Minimum allowable radius in mm
3	525
4	700
5	875
6	1050
8	1400

Table 27

Lexan Margard FMR5-E thickness in mm	Minimum allowable radius in mm
3	900
4	1200
5	1500
6	1800
8	2400

Fig. 31

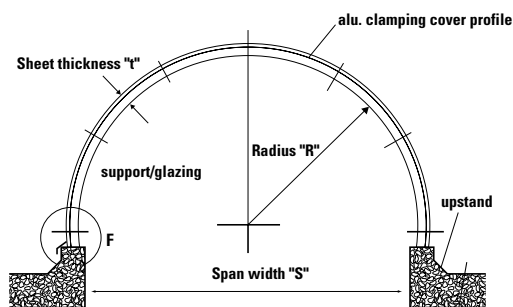

Note

Lexan 9030 sheet is recommended for internal curved glazing applications only.

Lexan Exell D ST sheet is suitable for curved privacy glazing: stair glazing, balcony glazing.

Lexan Exell D sheet is ideal for external architectural curved glazing applications: skylights, roofing.

Lexan Margard FMR5-E is recommended for curved revolving doors, partitions, walkways, etc.

Lexan Sheet curved glazing using standard metal profiles

This section illustrates the possibilities of curved glazing, combining standard profiles with Lexan sheet.

When specially developed patented glazing systems are not required, good possibilities still exist for Lexan sheet curved glazing by using standard metal profiles in combination with glazing tapes and non-hardening glazing compounds.

See page 13, Table 14 for suitable sealants.

This type of installation system is mainly used in small domestic type applications, carports, warehouses, conservatories and other glass replacement situations.

Fig. 32

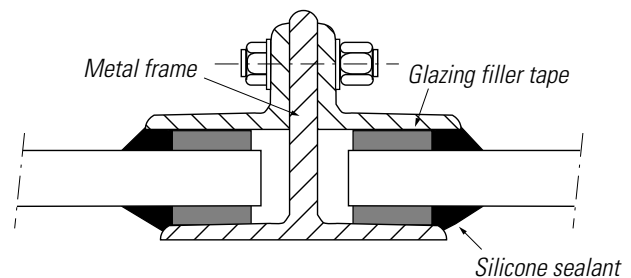

Lexan Sheet curved glazing using patented glazing systems

A wide range of patented glazing systems is commercially available. Many of these systems have already proved to be suitable for curved constructions in combination with Lexan sheet. Through close contact with system manufacturers and professional installers, GE Structured Products can advise and assist architects and engineers on the feasibility of a curved design concept with Lexan sheet in combination with a selected patented glazing system.

Metal or wooden structural support bars with a rubber gasket and an aluminium cover clamping strip with integrated rubber gaskets are often used. See page 13, Table 15 for suitable gaskets.

Fig. 33

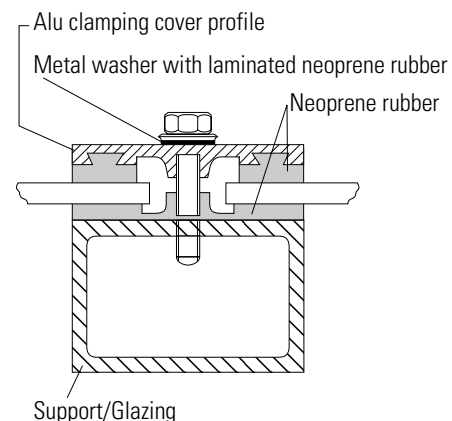

Curved Glazing Installation

Curved Glazing Sheet Thickness Selection

Curvature, as well as the span and curved profile distance, influence the cylindrical shell behaviour and the buckling load.

The critical load at which buckling occurs is calculated as a function of the shell geometry and the intrinsic properties of the Lexan sheet. With reference to the calculated linear buckling load as well as the stability, a safety factor of 1.5 is applied.

In this way correct sheet thickness and dimensions can be calculated under given load situations. The stiffness of Lexan sheet in curved glazing applications is mainly determined by the radius "R" and the distance "W" between the curved profiles. Sheet length "L" needs to be greater than sheet width "W" to facilitate curvature; in practice, a ratio of 1:2 or less is never contemplated because of the practicalities of installation.

Notes on Table 28

At a specified load the distance between the curved profiles can be found for different sheet thicknesses and radii. In the dark tinted section a maximum standard sheet width of 2.05 m may be used.

Fig. 34

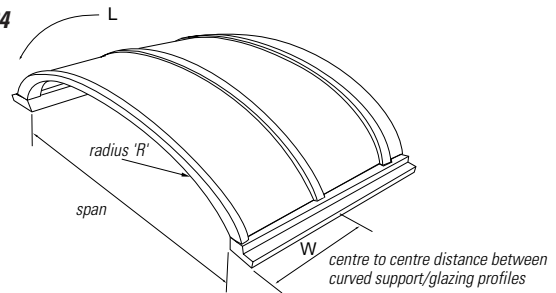

The light tinted section indicates that the curvature of relevant sheet thickness at that particular loading does not contribute any more to increased stiffness of the sheet. The stiffness of the sheet can be considered the same as flat sheet, and the last value is therefore applicable for all larger radii.

Table 29

Example:	
Roof-light Radius: 2800 mm	
Loading: 1000 N/m ²	
c.t.c. distance curved profiles	Lexan sheet thickness
400 mm	3 mm
530 mm	4 mm
650 mm	5 mm
1000 mm	6 mm
1950 mm	8 mm

Table 28: Centre to centre distance of curved support/glazing profiles in metres

		Radius in metres																									Loading in N/m ²			
		0.6	0.8	1.0	1.2	1.4	1.6	1.8	2.0	2.2	2.4	2.6	2.8	3.0	3.2	3.4	3.6	3.8	4.0	4.2	4.4	4.6	4.8	5.0	5.2	5.4		5.6	5.8	
Lexan Sheet thickness in mm	3	2.05	1.83	1.26	1.0	0.8	0.7	0.55	0.48	0.40																				
	4			2.05	2.0	1.62	1.35	1.15	0.97	0.85	0.75	0.68	0.6	0.55																
	5						2.05	1.98	1.68	1.45	1.3	1.15	1.03	0.95	0.88	0.8	0.74	0.68	0.63											
	6									2.05	2.0	1.8	1.6	1.46	1.34	1.24	1.14	1.05	1.0	0.9	0.85	0.8	0.75							
	8														2.05	2.0	1.85	1.72	1.6	1.5	1.4	1.3	1.24	1.18	1.14					
	3	2.05	1.34	0.98	0.76	0.6	0.5	0.44																						
	4		2.05	1.95	1.50	1.2	1.0	0.86	0.75	0.65	0.58	0.53																		
	5				2.05	1.75	1.48	1.26	1.1	0.98	0.88	0.8	0.73	0.67	0.6	0.56														
6					2.05	1.95	1.72	1.52	1.36	1.22	1.12	1.02	0.95	0.87	0.8	0.75														
8														2.05	2.0	1.85	1.72	1.6	1.5	1.4	1.3	1.22	1.17	1.1	1.05	1.0				
3	1.60	1.1	0.8	0.6	0.5	0.4																								
4		2.05	1.58	1.25	0.98	0.82	0.7	0.6	0.53																					
5				2.05	1.65	1.38	1.18	1.02	0.9	0.8	0.72	0.65	0.6																	
6					2.05	1.87	1.58	1.37	1.22	1.1	1.0	0.9	0.8	0.8	0.77	0.7														
8														2.05	1.95	1.8	1.63	1.5	1.4	1.3	1.2	1.13	1.06	1.0	0.94	0.9				
3	1.40	0.9	0.66	0.52	0.42																									
4	2.05	1.88	1.36	1.02	0.83	0.7	0.6	0.5																						
5				2.05	1.78	1.43	1.2	1.0	0.86	0.76	0.67	0.6																		
6					2.05	1.80	1.53	1.32	1.16	1.03	0.93	0.85	0.77	0.7																
8														2.05	1.85	1.66	1.50	1.38	1.28	1.17	1.1	1.02	0.96	0.9	0.86					
3	1.25	0.8	0.58	0.45																										
4	1.9	1.67	1.13	0.9	0.71	0.6	0.5	0.45																						
5			2.05	1.54	1.22	1.0	0.86	0.75	0.66	0.6																				
6				2.05	1.96	1.59	1.34	1.15	1.0	0.9	0.8	0.7																		
8														2.05	1.78	1.58	1.43	1.32	1.2	1.1	1.02	0.95	0.9	0.8						
3	1.02	0.7	0.51	0.4																										
4	1.65	1.36	1.0	0.8	0.64	0.53	0.45																							
5			2.05	1.7	1.32	1.07	0.9	0.8	0.66	0.6																				
6				2.05	1.66	1.38	1.17		1.0	0.9	0.8	0.7																		
8									2.05	1.75	1.57	1.42	1.27	1.15	1.06	1.0	0.9	0.85	0.8											
3	0.9	0.6	0.45																											
4	1.5	1.22	0.92	0.7	0.57	0.47																								
5			2.05	1.52	1.2	1.0	0.8	0.7	0.6																					
6				2.05	1.82	1.47	1.23	1.04	0.9	0.8	0.7																			
8								2.05	1.85	1.6	1.4	1.25	1.15	1.05	0.95	0.9	0.8													
3	0.84	0.56	0.42																											
4	1.35	1.12	0.82	0.64	0.51	0.43																								
5	2.05	1.8	1.4	1.1	0.9	0.7	0.62																							
6			2.05	1.68	1.35	1.12	0.96	0.83	0.7																					
8						2.05	1.9	1.6	1.45	1.27	1.14	1.03	0.94	0.86	0.8															

Americas

United States

GE Plastics
1 Plastics Avenue
Pittsfield, MA 01201
Tel. (1) (413) 448 5400

Brazil

GE Plastics South America
Av. Das Nacoes Unidas, 12995 - 20 Andar
Edificio Plaza Centenario
04578 - 000 Sao Paulo, Sp
Brazil
Tel. (55) 11 5505 2800
Fax (55) 11 5505 1757

Argentina

GE Plastics South America
Av. L.N. Alem 619 9 Piso
1001 Buenos Aires
Argentina
Tel. (54) 1 317 8753
Fax (54) 1 313 9560

Europe

The Netherlands

General Electric Plastics B.V.
Plasticslaan 1
PO Box 117
NL - 4600 AC Bergen op Zoom
The Netherlands
Tel. (31) (164) 29 27 42
Fax (31) (164) 29 19 86

United Kingdom

GE Plastics Ltd
Old Hall Road
Sale
Cheshire M33 2HG
United Kingdom
Tel. (44) (161) 905 50 01
Fax (44) (161) 905 50 04

Italy

General Electric Plastics Italia S.p.A.
Viale Brianza 181
I - 20092 Cinisello Balsamo (Mi)
Italy
Tel. (39) (02) 61 83 42 61
Fax (39) (02) 61 83 42 09

Germany

General Electric Plastics GmbH
Eisenstraße 5
D - 65428 Rüsselsheim
Germany
Tel. (49) (61 42) 601 101
Fax (49) (61 42) 601 259

Spain

GET sl (Gestión y Especificaciones Técnicas)
Agente Oficial España y Portugal
C/Girona, 67, 3º-2a
08009 Barcelona
Spain
Tel. (34) (93) 488 03 18
Fax (34) (93) 487 32 36

France

General Electric Plastics France S.à.R.L.
Z.I. de St. Guénault B.P. 67
F - 91002 Evry-Cedex
France
Tel. (33) (1) 60 79 69 00
Fax (33) (1) 60 79 69 21

Pacific

Australia

GE Plastics (Australia) Pty. Ltd.
175 Hammond Road
Dandenong, Victoria 3175
Australia
Tel. (61) 39 794 4204
Fax (61) 39 794 8563

Beijing

GE Plastics
Citic Building, 3rd Floor
No. 19 Jian Guo Men Wai Avenue
Beijing 100004
China
Tel. (86) 10 6500 6538
Fax (86) 10 6500 6476

Guangzhou

GE Plastics Guangzhou
Room 1212, Yi An Plaza
No. 38, Jian She 6 Road
Guangzhou, 510060
China
Tel. (86) 20 8387 2818
Fax (86) 20 3128 or 3118

Hong Kong

GE Plastics Hong Kong Ltd.
Rm 1008, Tower 1, The Gateway
25 Canton Road
Kowloon
Hong Kong
Tel. (852) 26 29 0880
Fax (852) 26 29 0801

Indonesia

GE Plastics Indonesia
Menara Batavia 5th Floor,
JI KH Mas Manjur kav.126
Jakarta 10220
Indonesia
Tel. (62) 21 574 4980
Fax (62) 21 574 7101

Japan

SP Pacific Ltd.
Nihonbashi Hamacho Park Bldg. 5th Floor
2-35-4 Nihonbashi Hamacho
Chuo-ku, Tokyo 103
Japan
Tel. (81) 3 569 6301
Fax (81) 3 569 6306

Korea

GE Plastics Korea Co. Ltd.
#231-8 Nonhyun-Dong
Kangnam-Ku
Seoul 135-010
Korea
Tel. (822) 510 6290
Fax (822) 510 6606

Shanghai

GE Plastics Shanghai
10th Floor, Shartex Center
88 Zunyi Road(s)
Shanghai 200335 China
Tel. (86) 21 6270 6789
Fax (86) 21 6270 9973
Fax (86) 21 6270 9974
Fax (86) 21 6270 9975

Singapore

GE Singapore
GE Tower, 240 Panjang Pagar Road
#500 Singapore 088540
Tel. (65) 326 3900
Fax (65) 326 3946

Taiwan

GE Plastics
13th Floor, #168
Tun Hua North Road
Taipei
Taiwan
Tel. (886) 2 514 9842
Fax (886) 2 514 9921

Thailand

GE Plastics Thailand
15th Floor, Thaniya Plaza Buiding
52 Silom Road, Bangkok 10500
Thailand
Tel. (662) 231 2918
Fax (662) 231 2322

All information, recommendation or advice contained in this document or given by General Electric Company*, USA, or any of its subsidiaries, affiliates or authorised representatives, whether written or oral, is given in good faith, to the best of its knowledge and based on current procedures in effect. The products of General Electric Company or, if applicable, of its subsidiaries or affiliates are sold subject to Conditions of Sale, printed on the back of order acknowledgements, invoice or available upon request. Nothing in this or any other document shall alter, vary, supersede or operate to waive any of the Conditions of Sale. Each user of the products shall convince himself, through all available sources (including finished product testing in its appropriate environment) of the suitability of the products supplied for its own particular purpose.

Because actual use of the products by the user is beyond the control of General Electric Company, its subsidiaries and affiliates, such use is within the exclusive responsibility of the user. General Electric Company, its subsidiaries and affiliates cannot be held responsible for any loss incurred through incorrect or faulty use of the products.

Information, recommendation and/or advice are neither made to infringe on any patents, nor to grant a license under any patent or intellectual property right of General Electric Company or any of its subsidiaries or affiliated companies, nor to grant the right to file for any patent protection.

Lexan®, and Valox® are Registered Trademarks of General Electric Co., USA.

www.GEStructuredProducts.com



GE Structured Products