

# DIN 85 / IS : 6101 - 1982 / ISO 1580

## Slotted Pan Head Screws

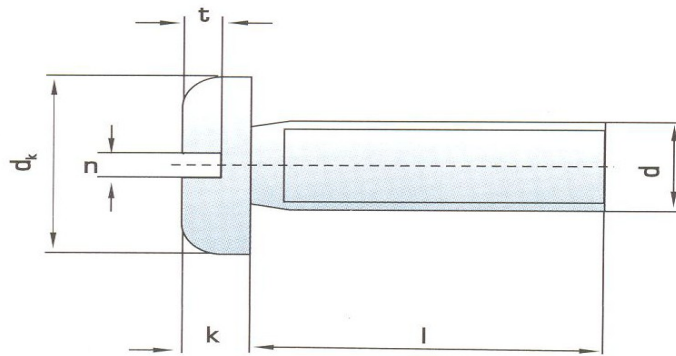

Thread size (d)	M 2	M 2.5	M 3	(M 3.5)	M 4	M 5	M 6	M 8	M 10	
Pitch	0.4	0.45	0.5	0.6	0.7	0.8	1	1.25	1.5	
$d_k$	max.	4	5	6	7	8	10	12	16	20
	min.	3.7	4.7	5.7	6.64	7.64	9.64	11.57	15.57	19.48
k	max.	1.3	1.5	1.8	2.1	2.4	3	3.6	4.8	6
	min.	1.16	1.36	1.66	1.96	2.26	2.86	3.3	4.5	5.7
n	min.	0.5	0.8	0.8	1.0	1.2	1.2	1.6	2.0	2.5
	max.	0.7	1	1	1.2	1.51	1.51	1.91	2.31	2.81
t min.	0.5	0.6	0.7	0.8	1	1.2	1.4	1.9	2.4	

\* All Dimension in mm

# BS 450 / 1958

## Pan Head Screws

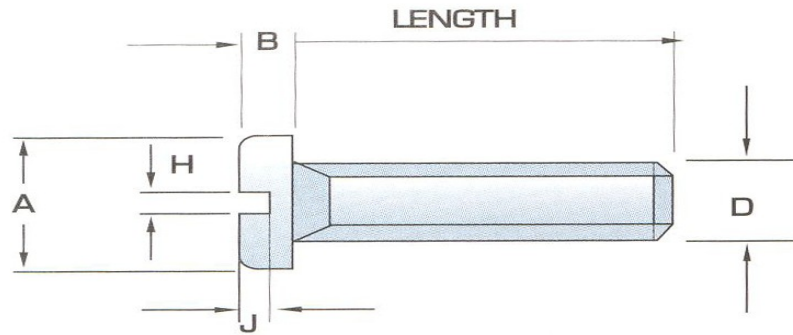

Nom. Size of Screw	Basic Diam. D	Threads per Inch B.S.W.	A		B		H		Depth of Slot J.
			Max.	Min.	Max.	Min.	Max.	Min.	
1/8	0.1250	40	0.245	0.231	0.075	0.005	0.039	0.032	0.040
3/16	0.1875	24	0.373	0.375	0.110	0.099	0.050	0.042	0.061
1/4	0.2500	20	0.492	0.473	0.144	0.130	0.061	0.051	0.078
5/16	0.3125	18	0.615	0.594	0.178	0.162	0.071	0.061	0.095
3/8	0.3750	16	0.740	0.716	0.212	0.195	0.082	0.072	0.112

\* All Dimensions in inch