

## Super Thin Round Chuck

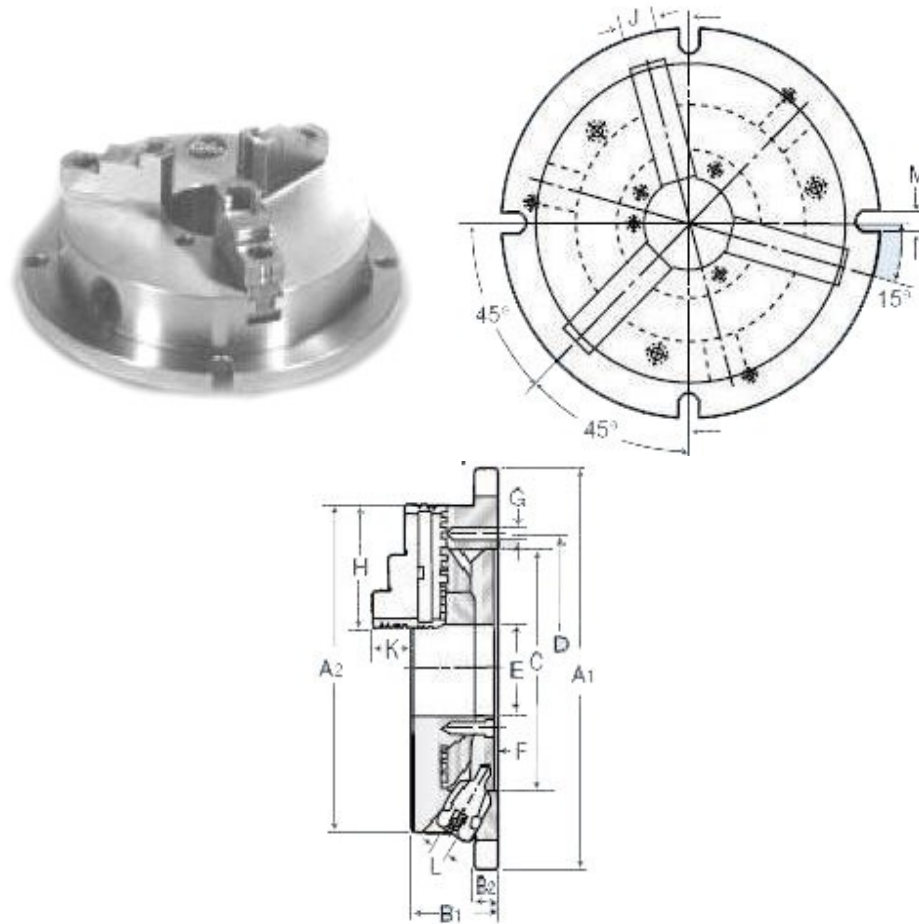

- The super thin Round Chuck gives 0.075mm TIR repeatability using the master pinion.
- The flanged type mounting makes it easy to load the chuck.
- The angle between "Handle" and "Base of Chuck" is 30 degree for good handle rotation.
- Soft Jaws are also available.
- Ideal fro Milling, VMCs, Drill Machines, Angle Plates Grinding Machines.

MODEL	A1	A2	B1	B2	C	D	E	F	G	H	J	K	L	M	Wt(kg)	Extr.	Inter.
M6	220	170	58	18	130	147	45	6	3M-10	68	26	40	10	10	11.0	8-160	48-150
M8	270	210	65	20	155	172	60	6	3M-10	82	28	45	11	13	19.5	11-200	62-190
M10	315	255	73	20	190	210	80	6	3M-12	93	32	52	12	16	29.5	12-250	72-240
M11	370	305	80	22	250	285	105	6	3M-12	117	40	59	14	18	42.5	15-300	86-290