

Energy Saving Band Heaters

MICA BAND HEATERS | MICA NOZZLE HEATERS | CERAMIC BAND HEATERS



Estd. 1988
Mumbai, INDIA

PRATIK HEAT PRODUCTS
PRIVATE LIMITED
MANUFACTURERS & EXPORTERS OF QUALITY INDUSTRIAL HEATING ELEMENTS

The first choice, to last...™



Energy Saving

Mica Band Heaters

PHP Mica Band heaters are available with or without outer heat saving insulation covers in various sheathing materials, viz. Chrome Nickel Steel, Brass, MS, depending upon applications which provides the best combination of physical strength, high emissivity & good thermal conductivity to heat cylindrical parts, good for sheath temperature upto 300°C.

Features

- Available in Premium, Economy & Power Saving Options
- Engineered for Uniform Temperature & Maximum Amperage carrying capacity
- Available in Brass, Chrome Nickel Steel & MS galvanized Sheathing
- Robust Terminal Junction with specially designed Chrome Nickel Steel protection cap to protect exposed terminals
- Special High Grade Mica insulation for Superior Thermal Conductivity
- Available in Various Lead Terminations & Clampings
- Conserves Energy with improved Heating Efficiency Up to 30 Watts per square inch
- Designed for Temperatures up to 300°C
- Expandable to fit around the Barral O.D. Easy installation & removal

Applications

- Injection Moulding
- Film extruders
- Blow Moulding
- Plastic & Rubber Processing Machinery
- Laboratory Equipment

4 Construction Styles To Choose From

1 ECO-HEAT CONSTRUCTION

- Chrome Nickel Steel Clamping with MS galvenised Inner Sleeve
- Single Piece Construction
- Screw Post terminal with Ceramic/Steel protection cap
- Clamping : Barrel Nut type
- Also available in Two Piece Construction



2 PREMIUM-HEAT CONSTRUCTION

- Chrome Nickel Steel Clamping with Brass / Chrome Nickel Steel inner Sleeve
- Single Piece Construction
- 500 mm Glass Fibre insulated Metal Braided Cable
- Terminal Protection Box, unless specified
- Clamping : Barrel Nut type
- Also available in Two Piece Construction



3 POWER SAVER CONSTRUCTION

- Chrome Nickel Steel Clamping with Brass / Chrome Nickel Steel Inner Sleeve
- Energy saving insulated cover
- Single Piece Construction
- 500 mm Glass Fibre insulated Metal Braided Cable
- Barrel Nut type clamping with Terminal Protection Box, unless specified
- Also available in Two Piece Construction



4 POWER SAVER PLUS CONSTRUCTION

- Chrome Nickel Steel Clamping with Brass / Chrome Nickel Steel Inner Sleeve
- Energy saving insulated jacket (16 mm)
- Single Piece Construction
- 500 mm Glass Fibre insulated Metal Braided Cable
- Barrel Nut clamping with Terminal Protection Box, unless specified
- Also available in Two Piece Construction



Technical Data

Sheath material	: Chrome Nickel Steel, Brass and MS (galvanised)
Insulation Material	: Mica
Heat Saving Insulation	: Ceramic Fibre Thermal Insulation
Heating Elements	: NiCr 60:16, NiCr 80:20
Post Terminals	: <750W 5/32" x 3/4", >750W 3/16" x 3/4"
Nominal Wall Thickness	: 4-5 mm (without insulating cover)
Connection Wire	: Fibre Glass Braided / Metal Braided (std. 500mm long)
Voltage Range	: 110V - 440V
Surface Loading	: Upto 30W / in ² (depending upon application)
Power Rating	: Depending upon application
Power Tolerance	: ±10%
HV Testing	: 1.5 Kv between heating element and sheath
Insulation Resistance (Cold)	: <20 M Ohms
Sheath Temperature	: Upto 300°C maximum (Chrome Nickel Steel sheath)

Limitations

Min. Inside Diameter	: 25 mm
Min. Width	: 25 mm without mounting / thermocouple holes 35mm with mounting / thermocouple holes
Tolerance Allowed	: Diameter: -2mm, Width: ±2mm, Resistance: +10%, - 5%, Wattage: +5%, - 10%,
Std. gap:	: 5-10mm
Limitations for 2 Piece Construction	: Min. I.D. : 3" Min. Width: 1½"

Suggested Watt Density Guide Lines

Diameter	: Suggested watt density
65 mm – 250 mm	: 20 -30 watt / sq. in
250 mm & above	: 18 – 25 watt / sq.in

Watt Density Formula for Mica Band Heaters

$$\frac{\text{Wattage}}{(\text{Heater I.D.} \times 3.14) - 0.75 \times \text{Width}}$$

Note: Max Suggested Watt Density is 30 W / sq in

Nominal Unheated Area

One piece construction	: 1" x width
Two piece construction	: 2" x width
Holes and Cutout	: size x ½"x width

Electrical Variations

SINGLE PHASE

PHP Band Heaters are usually designed on 230 V single phase unless specified.

DUAL PHASE

Mica Band Heaters can be designed with multiple circuits to operate in single or dual-phase circuits.





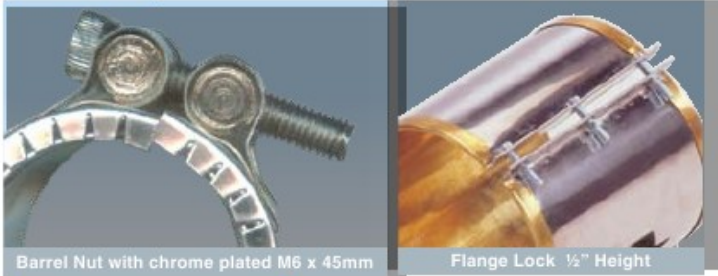

Clampings



Barrel Nut with chrome plated M6 x 45mm

Flange Lock 1/2" Height

Terminal Connection

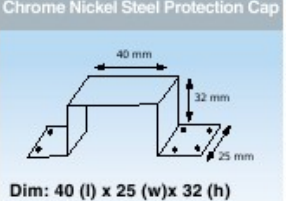
<p>2 Pin Male Plug 16Amps</p> 	<p>Chrome Nickel Steel Terminal Box</p>  <p>Dim: 40 (l) x 25(w) x 32 (h)</p>	<p>Chrome Nickel Steel braid existing both sides of gap.</p>  <p>Side View Front View</p>	
<p>Screw Post Terminals with Ceramic Protection Caps</p> 	<p>Chrome Nickel Steel Protection Cap</p>  <p>Dim: 40 (l) x 25 (w) x 32 (h)</p>	<p>Note: Electric Terminal Connections for Band Heaters will be Provided with Chrome Nickel Steel protection caps at center of width either at 180° opposite the Clamping or 90° from Clamping, unless specified. All Band Heaters above Dia 60mm will be provided with Screw Post Electric terminal connections covered with Chrome Nickel Steel Protection Caps. All Mica Band Heaters below 60mm Dia will not have Screw Post Terminals</p>	

Terminal Location

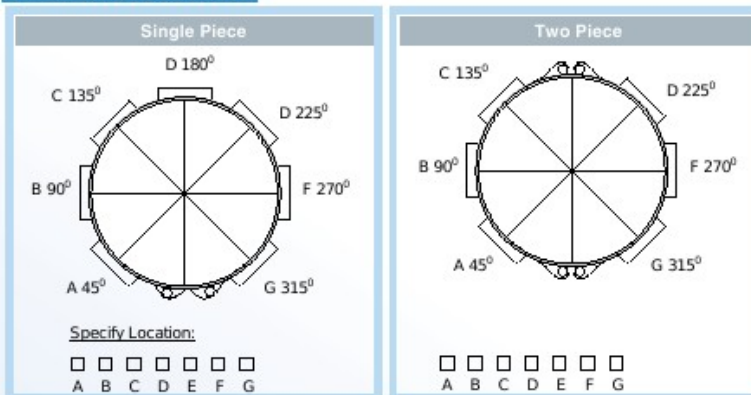

Thermocouple Holes/'U' Slots/Cutout

Normally required for clearance of the thermocouple probes or holding bolts. Oversize gap can in many cases serve the same purpose, using the centre of the gap as a starting point, specify location in terms of degrees and size of the hole or cut-out. Minimum of 1/2" is required from the hole to the edge of the heater. For critical hole or cut-out locations, please provide detailed drawing.

All Thermocouple Holes for Band Heaters (if required) will be Provided at center of width either at 180° opposite the Clamping or 90° from Clamping, unless specified along with drawing.

Note: As far as possible please avoid thermocouple holes. Try and locate them in the heater gap, since holes in the heater body complicates the internal wiring resulting in less heating area and also turns out to be more expensive.

OVERSIZE GAP

The nominal gap between the clamping is 5-10 mm. If a larger gap is required for probes or thermocouples, specify when ordering.



Thermocouple Holes Location (if required)

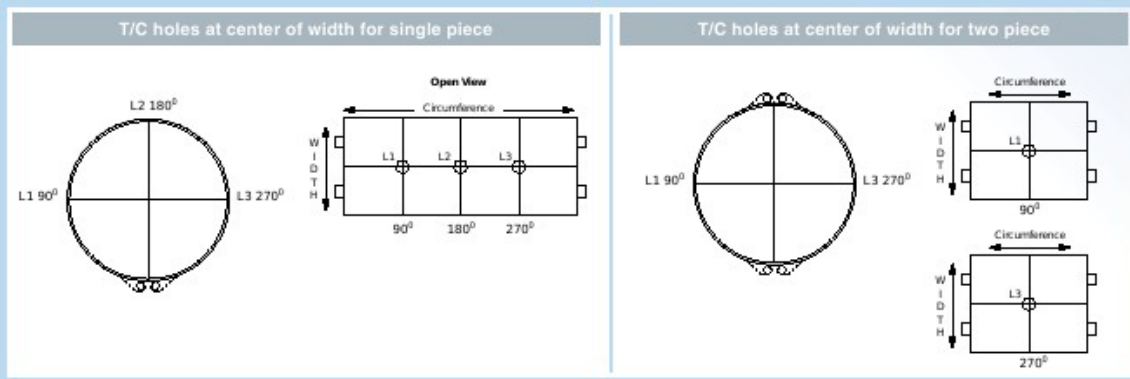

Two Piece Construction

Available on any screw or lead termination or clamping variation. Used on large cylinders or where heaters cannot be slipped over end of cylinders. Two piece Band Heaters are normally rated at half total wattage and full line voltage.

Limitations: Min. I.D. : 3" Min. Width: 1½"



How to order

When ordering please specify the following

- 1 Quantity
- 2 Inside diameter and width.
 - Inside Dia should be same as outer Dia of the cylinder to be heated
 - Width is the length of band heater.
- 3 Volts /Watts

Note: In case of 2 piece construction please specify wattage/wattage in each piece
- 4 Construction Style
 - Single piece construction
 - Two piece construction (Min ID – 3" min width –1.5")

IMP: Two Piece Band heaters are normally rated at half of Total Wattage & full line voltage unless specified

- 5 Construction Type
 - Eco Heat / Premium Heat / Power Saver Construction
- 6 Terminal Connection (Refer Pg 4)
- 7 Terminal location (Refer Pg 4)
 - Single piece construction/Two piece construction
- 8 Special holes or cut outs (please provide drawing of hole location.)

IMP: In case of thermocouple holes, mounting holes, "U" slots & cut outs (if any) please provide dimensional sketch.

Oversize Gap: If large gap is required for props or Thermocouple Hole, please specify along with the sketch
- 9 Required clamping (Refer Pg 4)

You can also log on to www.phpheat.com and order online.

Precautions & Installation for Mica Band Heaters and Mica Nozzle Heaters

- 1 Incorrect wiring and loose contacts leads to sparks resulting in fire or heater failure. Keep all electrical connections properly protected to avoid electrical hazards to machine operators.
- 2 Use of voltage stabilizers and circuit breakers ensures smooth supply of voltage to heaters resulting a longer life.
- 3 Ensure that the junction box is technically engineered to withstand the ampere load as well as the shocks and jerks due to movements. Appropriate connection leads (insulated) to withstand the required ampere load also reduce the risk of heater failure.
- 4 Improper installation of heaters on the barrel (lose fitting) that leads to hot spots. Band & Strip heaters are designed for contact heating & therefore must be tightly clamped to the object to be heated. The reason for this is that, as the heater heats up, it expands away from the surface to be heated causing air gaps resulting to poor heat transfer. Care should be taken to see that the heaters are placed squarely against the surface to be heated. In case of ceramic band heaters, take up all the slack by tightening outer housing until the serrated edges are firm and get uniform in contact with the cylinder. Do not over tighten where the edges begin to collapse which decrease the insulation value.
- 5 Ensure that the terminals are well insulated and protected since the heater terminals are prone to attracting moisture. Combustible gases & vapours also leads to deposits of carbon on the terminals resulting in failure of heaters.
- 6 Raw materials (polymers) spilling on the terminals & contamination (oil/grease) penetrating into the windings of the heaters. Prior to installation, the surface of the cylinder must be cleaned & should be free of all contamination that might liquefy under heat and penetrate into the windings thereby carbonizes & becomes conductive. The smallest amount of contamination can cause electrical shorts and result to heater failure.
- 7 Overheating that leads the heater to operate beyond the max capacity can be a cause for destroying an entire heating zone.
- 8 Defective temperature sensors and controllers. Choose the correct type of heaters, ie; Mica Insulated Band Heaters for applications upto max 400°C. The wattage should be calculated as close as possible to operating wattage to minimize on-off cycle resulting to power saving. Ensure that the tips of the sensors (Thermocouples) are clean and free from any contamination and should be checked for good response to temperature changes.
- 9 Use of substandard raw materials & manufacturing defects is also one of the common cause of heater failure.

