

PRODUCT RANGE : 8 mm TO 50 mm

TECHNICAL DATA	
1. CONSTRUCTION	: THREE PIECE, FULL BORE, BLOW-OUT PROOF STEM, FLOATING BALL, SOFT SEATED, NON-FIRE SAFE DESIGN BALL VALVE.
2. DESIGN & MFG. STD.:	BS 5351, API 602, IS 9890
3. INSPECTION & TESTING STD.	: BS 5146, API 598
4. END TO END	: ANSI B 16.10 (AS SHOWN)
5. END CONNECTION	: ANSI B 16.11
	A. SCREWED - BSP, BSPT, NPT
	B. SOCKET WELD

BILL OF MATERIALS

PART NO.	QTY.	NOMENCLATURE	MATERIAL
1	1	BODY	CI - IS 210 GR. FG 200 / 220 CS - ASTM A 216 GR. WCB SS - ASTM A 351 GR. CF8/CF8M SS - AISI 304/316
2	2	BODY CONNECTOR	CI - IS 210 GR. FG 200 / 220 CS - ASTM A 216 GR. WCB SS - ASTM A 351 GR. CF8/CF8M SS - AISI 304/316
3	1	BALL	ASTM A 351 GR. CF8/CF8M & AISI 304/316
4	1	STEM	AISI 304/316
5	2	BALL SEAT	AISI 304/316
6	2	BODY SEAL	PTFE
7	1	STEM SEAL	PTFE
8	3	GLAND PACKING	PTFE
9	2	GLAND	AISI 304/316
10	1	GLAND NUT	SS 304/Steel
11	1	WRENCH STOPPER	CI / CS / SS
12	1	WRENCH	SS 304/Steel Cd. Plated
13	1	WRENCH NUT	SS 304/Steel Cd. Plated
14	1	WRENCH SLEEVE	PVC
15	4/8	BODY STUDS & NUTS	SS 304/Steel Cd. Plated

TEST PRESSURE (psig / kg/cm ²)		
TESTING	BODY	SEAT
HYDRAULIC	435 / 30.5	320 / 22.5
PNEUMATIC	---	100 / 7

DIMENSIONS								
SIZE	FB	E/E	C/L	L/L	TS	TL	SB	SD
8	9	55	45	110	1/4"	10.5	14.4	10
10	9	55	45	110	3/8"	10.5	17.8	10
15	13	65	50	110	1/2"	13.5	21.8	10
20	1	70	65	130	3/4"	14	27.4	13
25	25	87	75	155	1"	17.5	34.1	13
40	38	105	90	170	1 1/2"	18.5	42.6	13
50	51	125	100	170	2"	19.5	49	13

- OTHER OPTIONS ON REQUEST:**
1. OTHER MATERIALS OF CONSTRUCTION
 2. 300# VALVES
 3. HOLLOW BALL
 4. PNEUMATIC OPERATION
 5. FIRE SAFE DESIGN

LEGEND : FB - FULL BORE, E/E - END TO END, C/L - CENTER TO LEVER, LL - LEVER LENGTH, TS - THREAD SURFACE, TL - THREAD LENGTH, SB - SOCKET BORE, SD - SOCKET DEPTH

VENUS FITTINGS & VALVES PVT. LTD.



MUMBAI OFFICE
897/911, John Roberts' Compound,
Sewri-Fort Road, Sewri (East),
Mumbai 400 015, Maharashtra (India).
Phone : (91-22) 2412 3151 / 2412 7006 Fax : (91-22) 2413 5576
E-mail : vfv@vsnl.net Website : www.vfv.com

AHMEDABAD OFFICE
8E, Sumeru Centre, Near Parimal Rly. Crossing, Paldi,
Ahmedabad 380 007, Gujarat (India).
Phone : (91-79) 2663 2754 / 2663 8877
Fax : (91-79) 2663 2754

WORKS
Sub Plot No. 1/2, Natraj Industrial Estate,
Village Wasna - Iyawa, Taluka - Sanand,
Dist. Ahmedabad 382 110, Gujarat (India).
Phone : (91-2717) 284392

THREE PIECE (3-PC.), FULL BORE, SCREWED OR SOCKET WELD ENDS, BALL VALVES, 150#

All dimensions are in mm

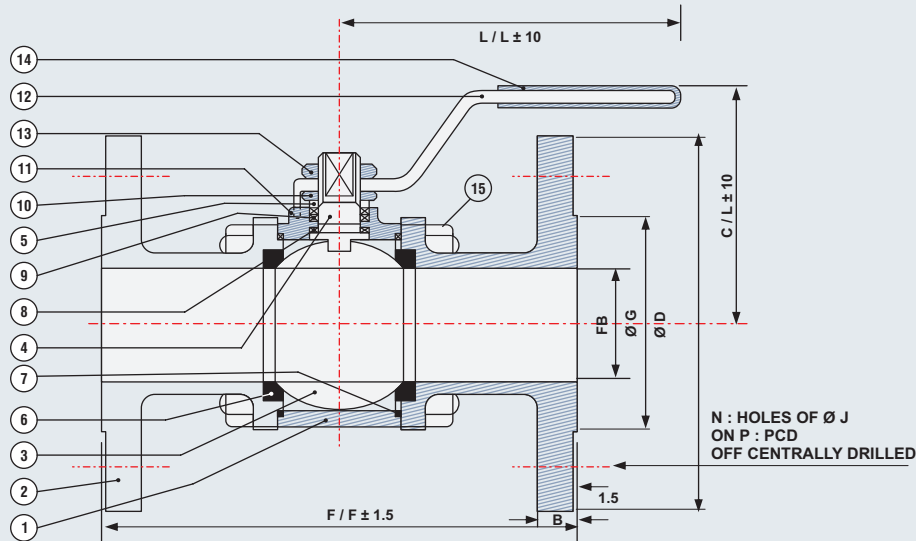

FLANGED ENDS

PRODUCT RANGE : 15 mm TO 100 mm	
TECHNICAL DATA	
1. CONSTRUCTION	: THREE PIECE, FULL BORE, BLOW-OUT PROOF STEM, FLOATING BALL, SOFT SEATED, NON-FIRE SAFE DESIGN BALL VALVE.
2. DESIGN & MFG. STD.:	BS 5351, API 602, IS 9890
3. INSPECTION & TESTING STD.	: BS 5146, API 598
4. FACE TO FACE	: ANSI B 16.10 (AS SHOWN)
5. END CONNECTION	: FLANGED AS PER ANSI B 16.5 RF

BILL OF MATERIALS			
PART NO.	QTY.	NOMENCLATURE	MATERIAL
1	1	BODY	CI - IS 210 GR. FG 200 / 220 CS - ASTM A 216 GR. WCB SS - ASTM A 351 GR. CF8/CF8M SS - AISI 304/316
2	2	BODY CONNECTOR	CI - IS 210 GR. FG 200 / 220 CS - ASTM A 216 GR. WCB SS - ASTM A 351 GR. CF8/CF8M SS - AISI 304/316
3	1	BALL	ASTM A 351 GR. CF8/CF8M & AISI 304/316
4	1	STEM	AISI 304/316
5	2	BALL SEAT	AISI 304/316
6	2	BODY SEAL	PTFE
7	1	STEM SEAL	PTFE
8	3	GLAND PACKING	PTFE
9	1	GLAND	AISI 304/316
10	1	GLAND NUT	SS 304/Steel
11	1	WRENCH STOPPER	CI / CS / SS
12	1	WRENCH	SS 304/Steel Cd. Plated
13	1	WRENCH NUT	SS 304/Steel Cd. Plated
14	1	WRENCH SLEEVE	PVC
15	4/8	BODY STUDS & NUTS	SS 304/Steel Cd. Plated

TEST PRESSURE (psig / kg/cm ²)		
TESTING	BODY	SEAT
HYDRAULIC	435 / 30.5	320 / 22.5
PNEUMATIC	---	100 / 7

DIMENSIONS										
SIZE	FB	F/F	C/L	L/L	Ø D	B	Ø G	P	N	Ø J
15	13	108	70	130	89	11.1	35	60.5	4	16
20	19	117	75	130	98.5	11.1	43	70	4	16
25	25	127	80	175	108	11.1	51	79.5	4	16
40	38	165	90	220	127	14.3	73	98.5	4	16
50	51	178	100	245	152.5	16	92	121	4	19
65	64	190	150	350	178	17.5	105	140	4	19
80	76	203	175	450	191	19	127	152.5	4	19
100	102	229	195	500	229	24	157	190.5	8	19

LEGEND : FB - FULL BORE, F/F - FLANGE TO FLANGE, C/L - CENTER TO LEVER, L/L - LEVER LENGTH, Ø D - RF DIA., B - THICKNESS WITHOUT RF, Ø G - INSIDE DIA.

OTHER OPTIONS ON REQUEST:

1. OTHER MATERIALS OF CONSTRUCTION
2. 300# VALVES
3. HOLLOW BALL
4. PNEUMATIC OPERATION
5. SIZES 150 mm & ABOVE
6. FIRE SAFE DESIGN

VENUS FITTINGS & VALVES PVT. LTD.



MUMBAI OFFICE 897/911, John Roberts' Compound, Sewri-Fort Road, Sewri (East), Mumbai 400 015, Maharashtra (India). Phone : (91-22) 2412 3151 / 2412 7006 Fax : (91-22) 2413 5576 E-mail : vfv@vsnl.net Website : www.vfvl.com	AHMEDABAD OFFICE 8E, Sumeru Centre, Near Parimal Rly. Crossing, Paldi, Ahmedabad 380 007, Gujarat (India). Phone : (91-79) 2663 2754 / 2663 8877 Fax : (91-79) 2663 2754	WORKS Sub Plot No. 1/2, Natraj Industrial Estate, Village Wasna - Iyawa, Taluka - Sanand, Dist. Ahmedabad 382 110, Gujarat (India). Phone : (91-2717) 284392	THREE PIECE (3-PC.), FULL BORE, FLANGED ENDS, BALL VALVES, 150# All dimensions are in mm
---	---	---	--