

MANUAL CHUCKS

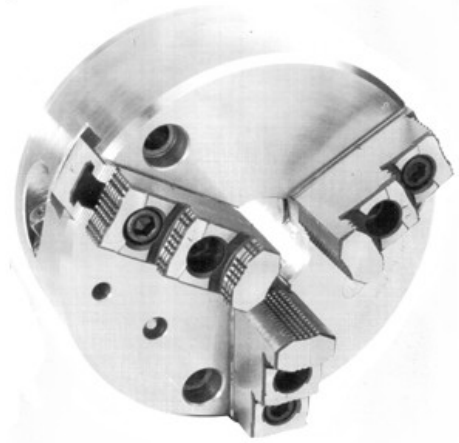
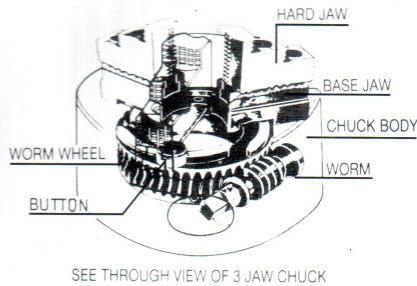

The production capacity of a lathe is entirely a function of the chuck used, the gripping power and the true running of the chuck.

A lathe with the excellently our chuck enhances the productive capacity of the lathe which which provides the answer to faster and better guaranteed production.

CONSTRUCTION:

The conventional bevel gear and the scroll have been replaced by a worm and wormwheel with three circular cams, to operate the jaws. The chrome case hardened wormwheel-cum-camring ensures maximum resistance to wear. The entire reaction of the clamping forces of the three jaws are confined in and taken up by the worm wheel-cum-camring and not by the chuck body or component parts.

The chuck body and the wormwheel-cum-camring are made from steel forgings, which provide the desired grain flow and thus minimise distortion under the clamping forces. All the parts are amply proportioned, made from high tensile alloy steels, hardened and ground wherever necessary, to close limits of accuracy. The hard jaws are provided with gripping serrations to grip the work piece firmly.

The normal dimensional variation in the gripping diameter of jobs is taken care of by the adequate stroke of the base jaws, thus avoiding frequent resetting of the false jaws.

On each circular cam, slides a chrome case-hardened button with a groove of the same radius as the cam. This provides a large pressure bearing area to the load transmitting surfaces. The large bearing surfaces reduces the stress per unit area to the minimum and completely inhibits any denting of the circular cam.

ADVANTAGES:

Because of the comparatively small number of well designed parts used in the chuck, frictional losses are reduced to minimum. The worm, wormwheel and the circular cam give the chuck an amazingly high mechanical advantage resulting in a grip many many times more powerful than that of a scroll chuck, for the same effort applied at the chuck key. Appropriate cam rise, combined with worm drive, ensures self locking action of the chuck over the entire clamping range and this guarantees the safety of the operator.

The top jaws are positively located on the base jaw by serrations ground after the jaws are case hardened. The top jaws can be quickly reset for different sizes of work pieces by merely loosening two socket head screws, shifting the jaw to the appropriate serration and retightening.

Three jaw chuck of sizes from 125 mm dia. to 315 mm dia. are offered with serrations of $1.5 \times 60^\circ$ on the base jaws.

Sizes 400 mm dia. to 800 mm dia are provided with 'V' Serrations of $3/32'' \times 90^\circ$.

SOFT JAWS:

Soft jaws are made from low carbon steel and used for second operation. They are used for gripping finished diameters and are supplied as blanks. They are reversible, so that both ends can be used.

The gripping diameters are to be machined in position on the chuck. This will ensure true running of the job on soft jaws, within close limits.

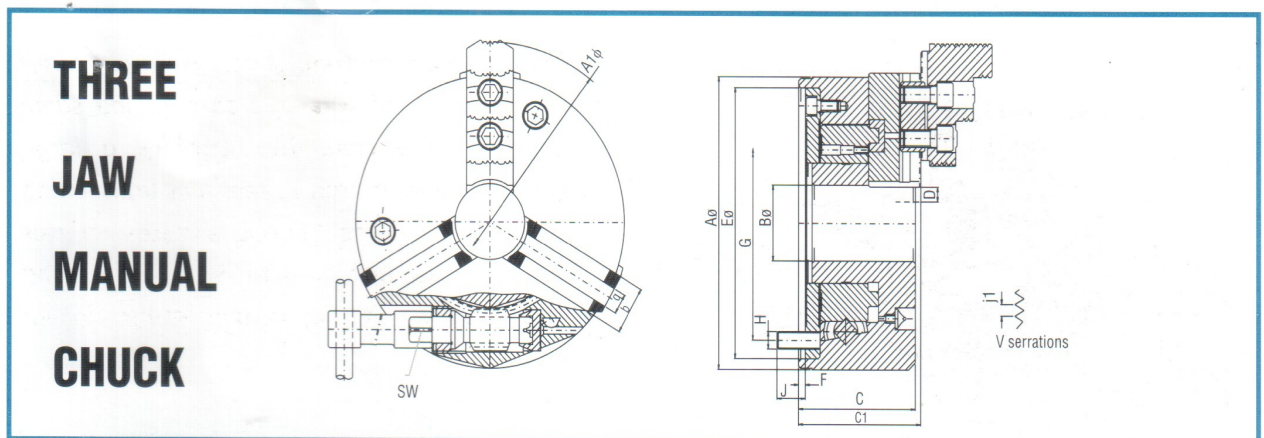

DIMENSIONAL SPECIFICATIONS:

Model	03-01	03-02	03-03	03-04	03-05	03-06	03-07	03-08	03-22	
Size Ø	125	160	200	250	315	400	500	630	800	
A Ø	125	160	200	250	315	400	500	630	800	
A 1 Ø Max	179	198	246	296	375	460	580	760	970	
B Ø	29	41	52	68	92	130	170	245	380	
C	62	83	87	100	113	116	126	147	161	
C 1	66	87	91	104	117	120	130	152	168	
D Jaw stroke	8	10	12	13	15	18	22	25	30	
E Ø H6	115	150	185	235	300	380	460	580	710	
F	3	5	5	6	6	6	6	6	7	
G	99.5	125	160	200	250	315	400	520	660	
H	2 x M8	2xM12	3XM1 2	3XM1 6	3XM 20	3XM2 0	3XM24	3XM24	3XM30	
J	15	15	21	23	24	21	36	35	48	
SW	8	11	14	17	19	19	24	24	24	
b	23	30	35	38	45	50	50	60	60	
J 1	1.5x6 0°	1.5x60°	1.5x6 0°	1.5x6 0°	1.5x 60°	3/32x 90°	3/32x90 °	3/32x90°	3/32x 90°	
q H7	8	12	14	17	21	21	21	25.5	22.5	
Outer Clamping	Max	125	160	200	250	315	400	500	630	800
	Min	8	10	12	14	16	18	30	50	150
Inner Clamping	Max	125	160	200	250	315	400	500	630	800
	Min	44	55	60	68	76	98	110	180	320
RPM Max.	3200	3000	2800	2200	180 0	1400	1100	900	600	
Wt. in Kgs.	7	12	19	35	58	110	180	307	490	

Each chuck is supplied with – one set of reversible hard jaws, one set of soft jaws, one number allen wrench for jaw screws, one chuck operating key with tammy bar and one set of body clamping screws.

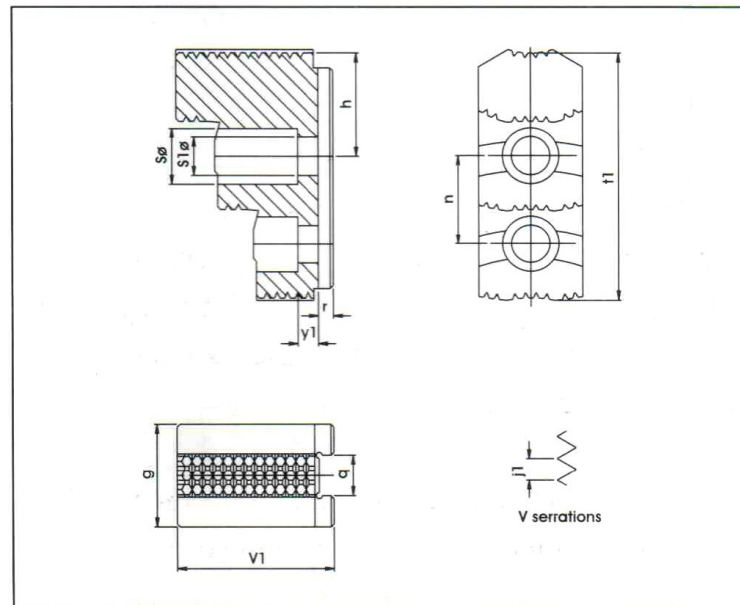

HARD JAW SPECIFICATIONS

Size	125	160	200	250	315	400	500	630	800
g	23	30	35	40	45	50	50	60	60
h	26.5	32	35	37	45	52	64	92	115
J1	1.5x60°	1.5x60°	1.5x60°	1.5x60°	1.5x60°	3/32x90°	3/32x90°	3/32x90°	3/32x90°
N	20	25	30	35	40	50	60	65	85/70
Qh7	8	12	14	17	21	21	21	25.5	25.5
r	3	5	5	5	5	5	5	5	5
S	10.5	17.5	19	23	25	25	25	31	31
S1	6.4	11	13	15	17	17	17	21	21
t1	61	70.2	83	95	112	132	163	197	246.5
V1	37	46	53	58	63	73	87	91	98
Y1	3.5	6.5	7	8	8	8	8	12	12

* 800 has 3 clamping holes Shaded sizes are special

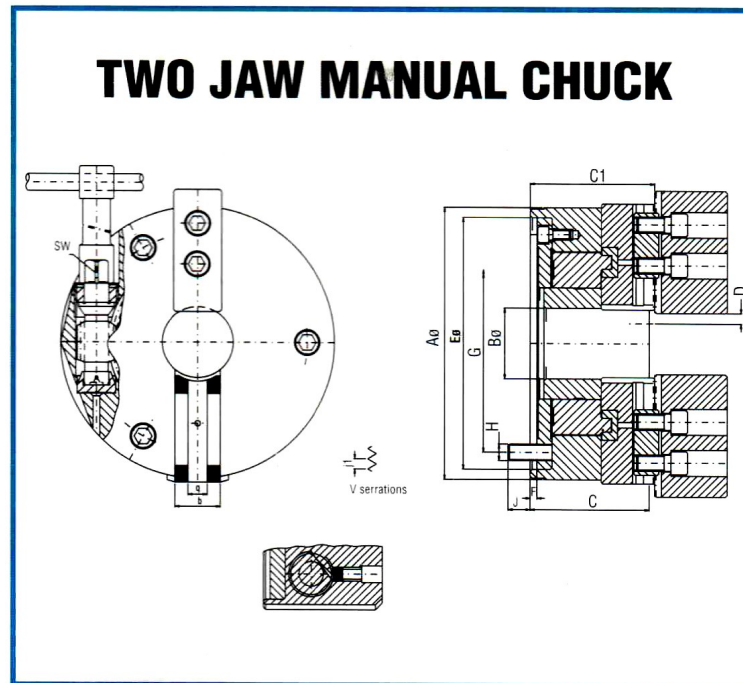

TWO JAW MANUAL CHUCK

Model	08-01	08-02	08-03	08-04	08-05	08-06	08-07	08-08
Size Ø	125	160	200	250	315	400	500	630
A Ø	125	160	200	250	315	400	500	630
B Ø	29	41	52	68	92	130	170	245

C	59	83	87	100	113	116	126	147
C1	63	87	91	104	117	120	130	152
D jaw stroke	8	10	12	13	15	18	22	25
EØH6	115	150	185	235	300	380	460	580
F	3	5	5	6	6	6	6	6
G	99.5	125	160	200	250	315	400	520
H	2XM8	2XM12	3XM12	3XM16	3XM20	3XM20	3XM24	3XM24
J	12	15	21	23	24	21	36	35
SW	8	11	14	17	19	19	24	24
b	23	30	33	38	45	50	50	60
J1	1.5x60°	1.5x60°	1.5x60°	1.5x60°	1.5x60°	3/32x90°	3/32x90°	3/32x90°
Qh7	8	12	14	17	21	21	21	25.5
RPM Max.	3200	3000	2800	2200	1800	1400	1100	900
Wt. in Kgs. approx	10	13	21	38	62	115	321	355

Each chuck is supplies with –One set of soft jaws. One number alien wrench for jaw screws. One number chuck operating key with tommy bar and one set of body clamping screws.

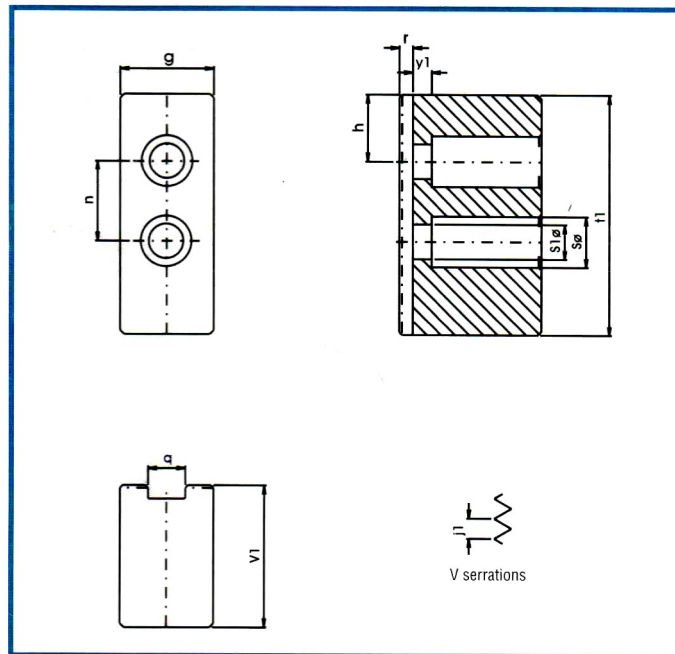

SOFT JAW SPECIFICATIONS FOR TWO JAW AND THREE JAW CHUCK

Size	125	160	200	250	315	400	500	630	800	
g	2 jaw	28	55	55	60	65	78	78	80	-
	3 jaw	28	35	35	40	45	50	50	60	60

h	21	22.5	25	29.5	30	40	40	70	70
j1	1.5x60°	.5x60°	1.5x60°	.5x60°	5x60°	3/32x90°	3/32x90°	3/32x90°	3/32x90°
n	20	25	30	35	40	50	60	65	85/70*
qh7	8	12	14	17	21	21	21	25.5	25.5
r	3	5	5	5	5	5	5	5	5
s	10.5	16.75	19	23	25	25	25	31	31
s1	6.4	10.5	13	15	17	17	17	21	21
t1	67	80	90	110	130	160	190	225	275
v1	44	53	53	58	63	76	87	91	98
y1	7	7.5	7	8	8	8	8	12	12

* 800 has 3 clamping holes Shaded sizes are special